

techo[®]

ROYAL AHREND COMPANY

[_product catalogue_](#)



WORK DESKS

4EVER



Are you looking for an office desk that does everything you want, but at the same time is very simple in appearance and concept? This is precisely what the 4Ever desk system offers – intuitive design, not overstated; a system for everyone. Its defining feature is the removable desktop. The 4Ever desking system is able to fulfil the requirements of even the most demanding installations. As well as separate workstations, it can also be used to create bench style work environments – offering you room to grow your company. One desk can be used for one, two or even four to six workers. Configurations can be constructed from the individual desk modules. The desk is also height adjustable, which will please tall people and anyone wanting easy access to the cable management under the desktop.

4EVER

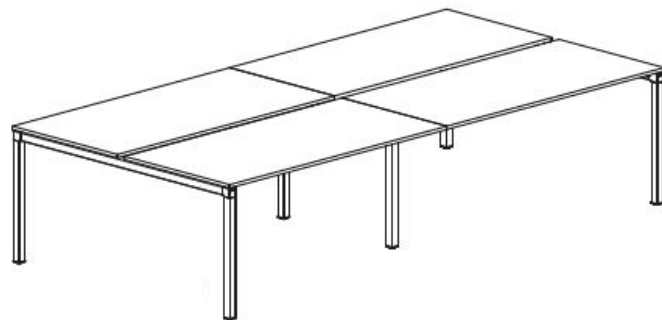
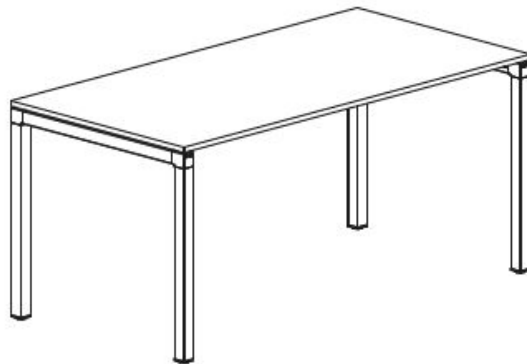

Technical details

- » Square section legs: 45 x 45 mm
- » Laminated desktop with 2mm ABS edge
- » Thickness: 18 mm
- » Levelling of the desk: 735 - 750 mm
- » The base is finished with a high-quality powder paint coating

Desktop colors:

- » We offer a wide range of decors from suppliers Egger, Pfleiderer and Kronospan.

Base colors:

- » Black
- » Gunmetal
- » White
- » Silver

Options:

- » Removable desktop for easy assembly
- » Height adjustable option with screw leg adjustment 660 – 880 mm
- » Bench workstations
- » Hybrid version with pedestal supporting the desk at one end
- » The availability of a range of dimensions incl. conference size (see the technical manual in the download section)
- » Accessories are also available such as screen holders, cable channels, integrated power supply, horizontal clips
- » Part of the desktop can be raised to give better access to the cable channel
- » It can be combined with TECHO pedestals and storage systems to create a workstation unit

4EVER A



The 4Ever A office desk meets all your requirements down to the last detail. Thanks to its detachable desktop it is easy to create work space for individuals, bench workstations or conference tables. It can be produced to suit your specific requirements and the size of your team. Its intuitive minimalist design also means it will fit in well with any office. It is not by chance that this desk bears the name 4Ever A – they really will stand the test of time.

The desk base comprises stretchers and side pieces - the side pieces consist of 45 x 45 mm square-section legs, a top piece and the aluminum corners that are the dominant design feature and are always finished in silver. In the case of 4Ever A, the legs are angled into an A-shape. The standard desktop is made from laminated chipboard with a plastic edge that is applied using laser technology. Metal parts are finished with a powder paint coating.

4EVER A

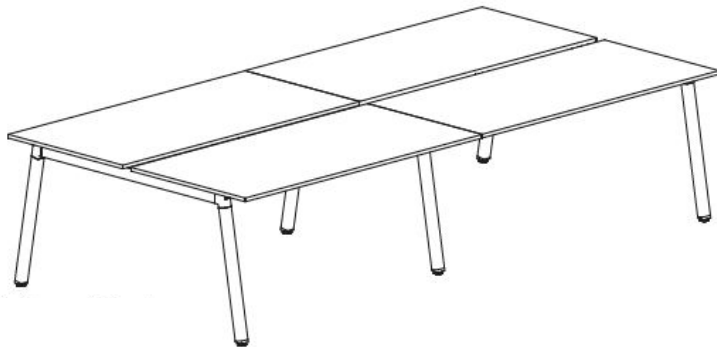

Technical details:

- » Square section legs: 45 x 45 mm
- » Laminated desktop with 2mm ABS edge
- » Thickness: 18 mm
- » Levelling of the desk: 735 - 750 mm
- » The base is finished with a high-quality powder paint coating

Desktop colors:

- » We offer a wide range of decors from suppliers Egger, Pfleiderer and Kronospan.

Base colors:

- » Black
- » Gunmetal
- » White
- » Silver

Options:

- » Removable desktop for easy assembly
- » Height adjustable option with screw leg adjustment 660 – 880 mm
- » Bench workstations
- » Hybrid version with pedestal supporting the desk at one end
- » The availability of a range of dimensions incl. conference size (see the technical manual in the download section)
- » Accessories are also available such as screen holders, cable channels, integrated power supply, horizontal clips
- » Part of the desktop can be raised to give better access to the cable channel
- » It can be combined with TECHO pedestals and storage systems to create a workstation unit

ARKUS A



Functionality and aesthetic appearance, simplicity and flexibility are all characteristics of the contemporary workplace, which are embodied in the Arkus office desk. It has been designed to appear modern regardless of the changing workplace trends. We make no apologies for the fact that we refuse to compromise the pure function of our desking systems by following trends or fads. It is a functional desking system that allows the workplace atmosphere to be moulded and shaped according to the wishes of the interior designer.

ARKUS A



Technical details:

- » The metal base is finished with a high-quality powder paint coating
- » The EKOTECH wood fiber board with lacquered edges and optional chamfer optically complements the slim appearance of the Arkus desk system
- » Thickness: 17.6 mm
- » Laminated desktop with 2 mm ABS edge
- » Thickness: 18 mm
- » Levelling adjustment: 735 - 750 mm

Desktop colors:

- » We offer a wide range of decors from suppliers Egger, Pfleiderer and Kronospan.

Base colors:

- » Black
- » Gunmetal
- » White
- » Silver

Options:

- » Unifying interior when using both versions (desk and conference table) together
- » Option of integral power supply and cable management

ALFA UP



At TECHO it is quality above all that is important, and this is reflected in the well-designed Alfa Up desk system. It is a very practical desk, in particular thanks to its height-adjustable legs and synchronous lifting mechanism that enables you to work both sitting and standing. This is a very healthy and modern way of working in an office thanks to which you can quickly change your work stance without interrupting your work. ALFA UP is stable and durable with a quiet mechanism. It can be assembled in just 7 minutes. The height-adjustable legs are three-stage telescopic with a high quality powder paint finish. The desk also has an intelligent protection system (IPS) and the base is electrically operated with a control unit and panel. With regards to the control panel you can choose between the basic version with two buttons, and two advanced panels with display and memory. Other options include an anti-collision sensor

ALFA UP



Technical details

- » Square section legs: 45 x 45 mm
- » Laminated desktop with 2mm ABS edge
- » Thickness: 18 mm
- » Levelling of the desk: 735 - 750 mm
- » The base is finished with a high-quality powder paint coating

Desktop colors:

- » We offer a wide range of decors from suppliers Egger, Pfeiderer and Kronospan.

Base colors:

- » Black
- » Gunmetal
- » White
- » Silver

Options:

- » Removable desktop for easy assembly
- » Height adjustable option with screw leg adjustment 660 – 880 mm
- » Bench workstations
- » Hybrid version with pedestal supporting the desk at one end
- » The availability of a range of dimensions incl. conference size
- » Accessories are also available such as screen holders, cable channels, integrated power supply, horizontal clips
- » Part of the desktop can be raised to give better access to the cable channel
- » It can be combined with TECHO pedestals and storage systems to create a workstation unit

W.O.T. EXECUTIVE



In this exclusive range the desktop is actually the major structural component of the desk itself. All other supporting and load bearing components common for office desks have been eliminated. Thanks to this our desk system has a more traditional appearance that evokes a feeling of continuity between modern innovations and traditional crafts.

The WOT Executive desk was created specifically with managers in mind. With its stylish design, free of any separate beams or supports, it will help to create the ideal executive working environment.

Cables on a classic desk are the worry lines and wrinkles that can spoil the perfect look. No plastic surgery required here though – just clever cable management to preserve the elegance of WOT.

W.O.T. EXECUTIVE

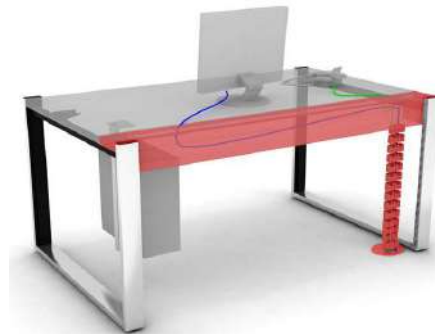
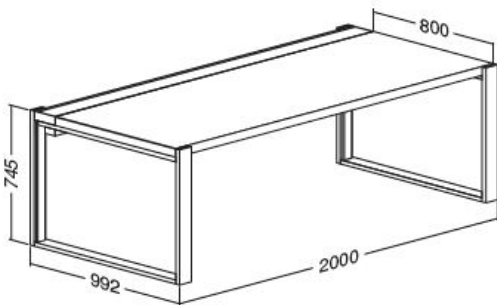

Technical details

- » Honeycomb top" (LIGHTBOARD) with HPL foil and ABS edge 2 mm.
- » Metal base finishes
- » Thickness 40mm
- » The aluminum profiles used in the construction is finished with a high-quality powder paint coating

Decors and colors

- » The HPL used on the WOT Executive is very high quality and gives a faithful impression of a veneer finish. However, in comparison with veneer it is much more hard wearing. The desktop surface has a relief structure finish.
- » H1424 ST22 – Woodline creme
- » H1428 ST22 – Woodline mokka
- » Polished aluminum in combination with RAL9010 – white
- » Polished aluminum in combination with RAL9004 – black
- » The polished aluminum mimics a chrome finish.

Options

- » A wide range of accessories available – screens incl. holders, vertical and horizontal cable management, CPU holders
- » Combining with WOT pedestals and storage products, WOT system creates an unified workstation

MEHES



Mehes is a distinctive furniture system that fits in any room. Stylish. Flexible. Timeless. The transparent design accentuates the right furnishing and architectural elements. The elegant transparency is achieved by making use of a 12-mm thin, 'floating' worktop carried by thin I-shaped legs, connected by an aluminum worktop rail with a worktop support. Mehes epitomizes quality in all respects. A maximum effect is created using a minimum number of parts. Both subtle and rich.

MEHES



Basic model:

- » Workstation, linking table and conference table configurations
- » Aluminum/steel I, T and C-legs, linked by an aluminum worktop rail and worktop support
- » 12-mm thick Ciranol worktop

Technical details:

- » Frame and legs in standard Ahrend lacquer colors
- » Fixed legs: heights 72 and 74 cm
- » Height-adjustable legs: 62 - 82 cm

Options:

- » Cabling facilities
- » CPU holder

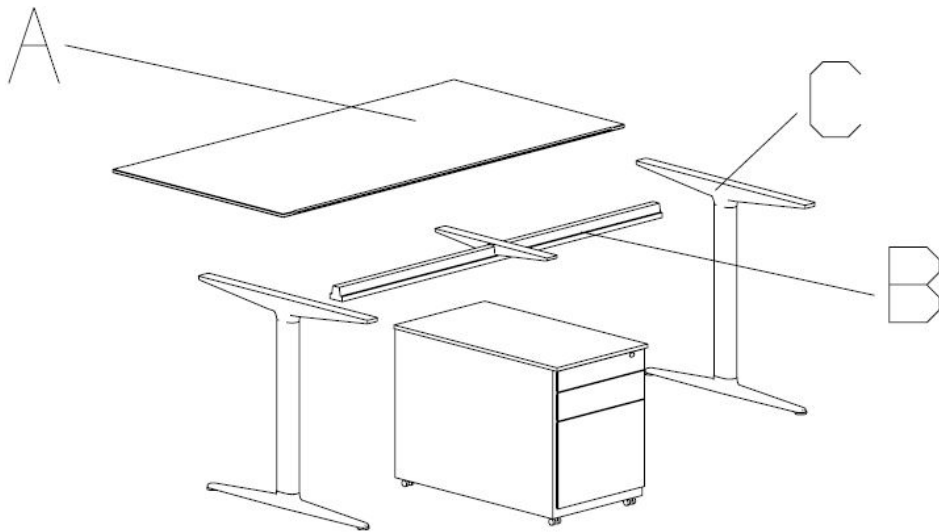



CONFERENCE TABLES

FORUM



The Forum conference table dispels the standard notion of what office furniture should look like. Its uniqueness of appearance is derived mainly from the solid ash legs, which brings a touch of nature to the meeting room, and creates a very pleasant and homely environment for work and personal meetings. Despite its robust appearance, the table maintains a very modern and minimalist design, which makes it the ideal choice for every interior. The base comprises longitudinal stretchers and end legs from solid wood (ash), which enable the table to look at home in both commercial and domestic settings. Steel structural elements are inset into the wood and these ensure a firm connection with the lengthways supports. The chipboard-based table top with HPL has plastic edges. For a higher standard appearance the laminate PerfectSense Topmatt is available as an option, which provides exceptional resistance to fingerprints, wear and tear and scratching.

FORUM



Technical details:

- » Table height: 740 mm
- » Minimum desk dimensions:
1000 x 1000 mm (width x length)
- » Maximum desk dimensions:
1400 x 3000 mm (width x length) – standard MFC
1300 x 3000 mm (width x length) – Topmatt
- » Laminated table top with ABS edge 2 mm
- » Thickness: 25 mm
- » Metal parts of the base are finished with an epoxy polyester powder coating

Desktop colors:

- » Standard MFC - we offer a wide range of decors from suppliers Egger, Pfleiderer and Kronospan
- » Topmatt – Black, Stone Gray – high scratch resistance, super-matt, warm and velvety texture with anti-fingerprint effect

Base colors:

- » Wood (ash)
- » Metal (white)

Options:

- » Two table top options – MFC, Topmatt
- » Available in a range of sizes
- » Accessories are also available such as screen holders, cable channels, power sockets, horizontal clips

TOGETHER



Would you like to create a pleasant and professional environment for discussions with clients? The TOGETHER conference table will bring you a step closer to this objective. It combines maximum practicality with a simple and clean design, which ensures perfect connection with all surrounding interior elements. With this table you transform any meeting into a comfortable experience that will satisfy your clients. The design of the base differs depending on the type of table. The central stainless-steel four-arm base with X-shaped desk support is used only for round tables. For rectangular desks leg sets are used at each end, and in the case of large tables, also central legs – the legs for a design element with the V-shaped double arms. The rigidity of the table is ensured by metric screws that connect the base structure to the table top supports. The table top is made from chip board with a standard laminate, or the option PerfectSense Topmatt, which is resistant to fingerprints, wear and tear and scratching. Both types of table top have a plastic edge.

TOGETHER



Technical details:

- » Desk height:
 - 744 mm (table top thickness 18 mm)
 - 751 mm (table top thickness 25 mm)
- » Minimum dimensions for table with central base:
 - 800 x 800 mm (width x length)
- » Diameter 800 mm
- » Maximum dimensions of table:
 - 1300 x 2000 mm (width x length – 1x table top, 2x end legs)
 - 1300 x 4000 mm (width x length – 2x table top, 2x end legs, 1x central leg)
- » Laminated table top with 2mm ABS edge
- » Thickness: 18 mm in standard laminated finish
- » Thickness 25 mm in finish Topmatt
- » Metal parts of the base have an epoxy-polyester powder coating in combination with chrome

Desktop colors:

- » We offer a wide range of decors from leading suppliers Egger, Pfleiderer and Kronospan.
- » Base colors:
 - » T-shaped steel construction: black
 - » Legs: chrome

Options

- » Selection of various table top options
- » Availability in various dimensions and a folding version
- » Accessories are also available such as screen holders, cable channels, power sockets, horizontal clips

TOGETHER FOLDING

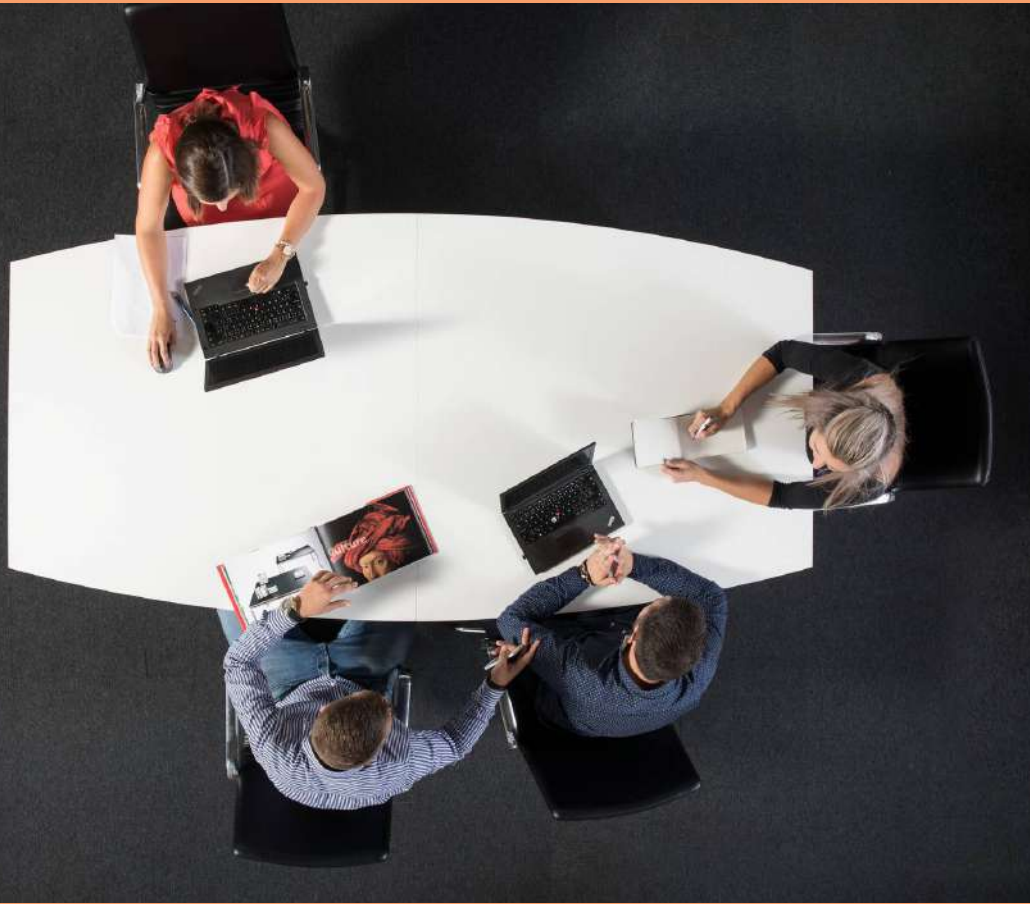

Would you like to create a pleasant and professional space for large meetings with clients? Do you organise conferences and frequently have to rearrange your space according to requirements, but you don't have sufficient storage space? In such case the TOGETHER folding conference table is the ideal choice for you. It combines maximum practicality with a simple and clean design, which ensures perfect connection with all surrounding interior elements. This table transforms any meeting into a comfortable experience that will satisfy your clients. The table has a frame made from welded-stainless steel base with two V-shaped arms and a steel T construction, which is attached firmly to longitudinal table top supports. The table top is made from laminated chipboard or as an option PerfectSense Topmatt, which provides exceptional resistance to fingerprints, wear and tear and scratching. Both of these options are fitted with plastic edges.

TOGETHER FOLDING

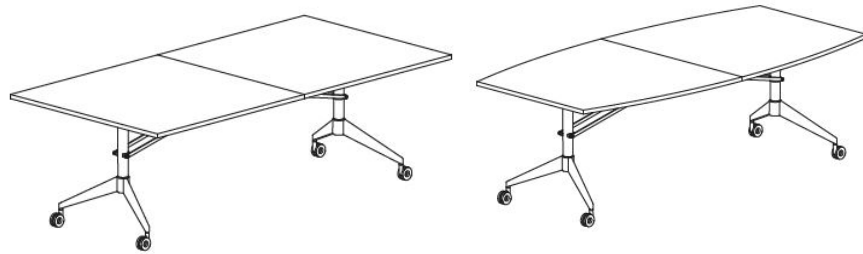

Technical details

- » Table height: 751 mm
- » Dimensions for the version with table top Barrel:
 - Minimum table dimensions: 1050 x 2200 mm (width x length)
 - Maximum table dimensions: 1200 x 2400 mm (width x length)
- » Dimensions for rectangular table:
 - Minimum table dimensions: 750 x 2200 mm (width x length)
 - Maximum table dimensions: 1200 x 2400 mm (width x length)
- » Laminated table top with 2 mm ABS edge
- » Thickness: 25 mm
- » The metal parts of the base have an epoxy-polyester powder coating in combination with chrome.

Desktop colors:

- » We offer a wide range of decors from suppliers Egger, Pfleiderer and Kronospan.
- » Base colors:
 - » Base: black
 - » Legs: chrome

Options:

- » Selection of two table top versions
- » Availability in various dimensions

AERO



The Aero table comes into its own in every type of work environment. From homely to agile work environments; this table serves as the perfect place for scrum teams or brief meetings. Therefore the table is ideal for collaborative meetings, whether sitting or standing. The recessed A-shaped table legs provide full leg freedom and give the table a casual yet chic look.

Intelligent table range for informal meetings and Collaborative Working.

The recessed A-shaped table legs offer ample leg room and give the table an informal and chic look.

Very stable construction that allows big spans.

Unique rotatable leg design available in wood or steel. Oak table legs create a homely feel.

AERO

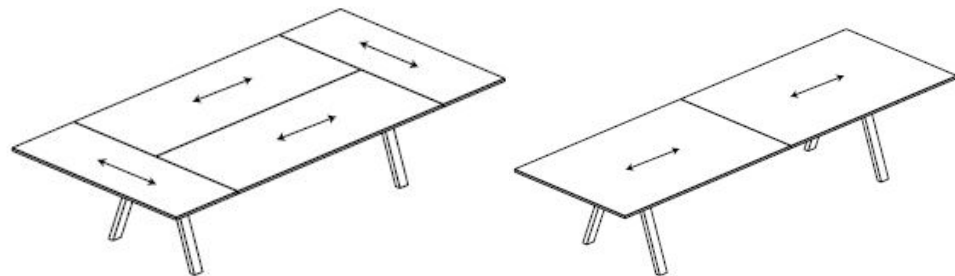

Dimensions

- » Various depth dimensions up to 160 cm
- » Various width dimensions up to 520 cm
- » Surrounded support rectangular steel sheet frame, with 600 mm overhang on table tops
- » Table top of 22 mm Monotop with laser-cut edges
- » 12 mm Ciranol (HPL) in various finishes
- » Tables equipped with main table tops
- » Option of positioning table legs either straight or angled at 45 degrees
- » Table legs and frame in standard Ahrend lacquer colors

Technical details:

- » Sitting height of 75 cm and fixed standing height of 110 cm
- » Rectangular steel tube legs attached to the frame
- » 2 depths for - 80 cm or 100+ cm
- » Rotatable table legs as standard on standing height tables
- » Steel leg with adjustable foot and facility to integrate cables
- » Wooden feet with felt glides

Options

- » Tables available in stand height
- » Wooden frame in matt oak
- » 12 mm Ciranol (HPL) in various finishes
- » Plug & play via complete cable-management
- » Integrated LED table lamp with shade available in 3 colors
- » Dividing elements for more privacy



HIGH TABLES

ALFA 200



Sleek high table that is a perfect fit for the cafeteria environment and much more. Alfa 200 also serves as a good partner for informal meetings, coffee breaks and project discussions and thanks to its minimalistic design will complement any type of working or living spaces.

ALFA 200



Technical details

- » Extremely stable X base
- » Modern steel frame
- » Great performance/price value
- » 25 mm MDF desktop
- » Certain patterns with possibility of laser edges

Desktop colors:

- » We offer a wide range of decors from suppliers Egger, Pfleiderer and Kronospan.

Base colors:

- » Gunmetal
- » White



AERO HIGH



Sleek high table that is a perfect fit for the cafeteria environment and much more. Alfa 200 also serves as a good partner for informal meetings, coffee breaks and project discussions and thanks to its minimalistic design will complement any type of working or living spaces.

AERO HIGH



Base options

- » Various depth dimensions up to 160 cm
- » Various width dimensions up to 520 cm
- » Tables equipped with main table tops
- » Surrounded support rectangular steel sheet frame, with 600 mm overhang on table tops
- » Option of positioning table legs either straight or angled at 45 degrees
- » Table top of 22 mm Monotop with laser-cut edges
- » Table legs and frame in standard Ahrend lacquer colors

Technical details

- » Standing height of 110 cm
- » Rectangular steel tube legs attached to the frame
- » 2 depths for - 80 cm or 100+ cm
- » Rotatable Rotated table legs as standard on standing height tables
- » Steel leg with adjustable foot and facility to integrate cables
- » Wooden feet with felt glides

Options

- » Wooden frame in matt oak
- » 12 mm Ciranol (HPL) in various finishes
- » Plug & play via complete cable-management
- » Integrated LED table lamp with shade available in 3 colors
- » Dividing elements for more privacy



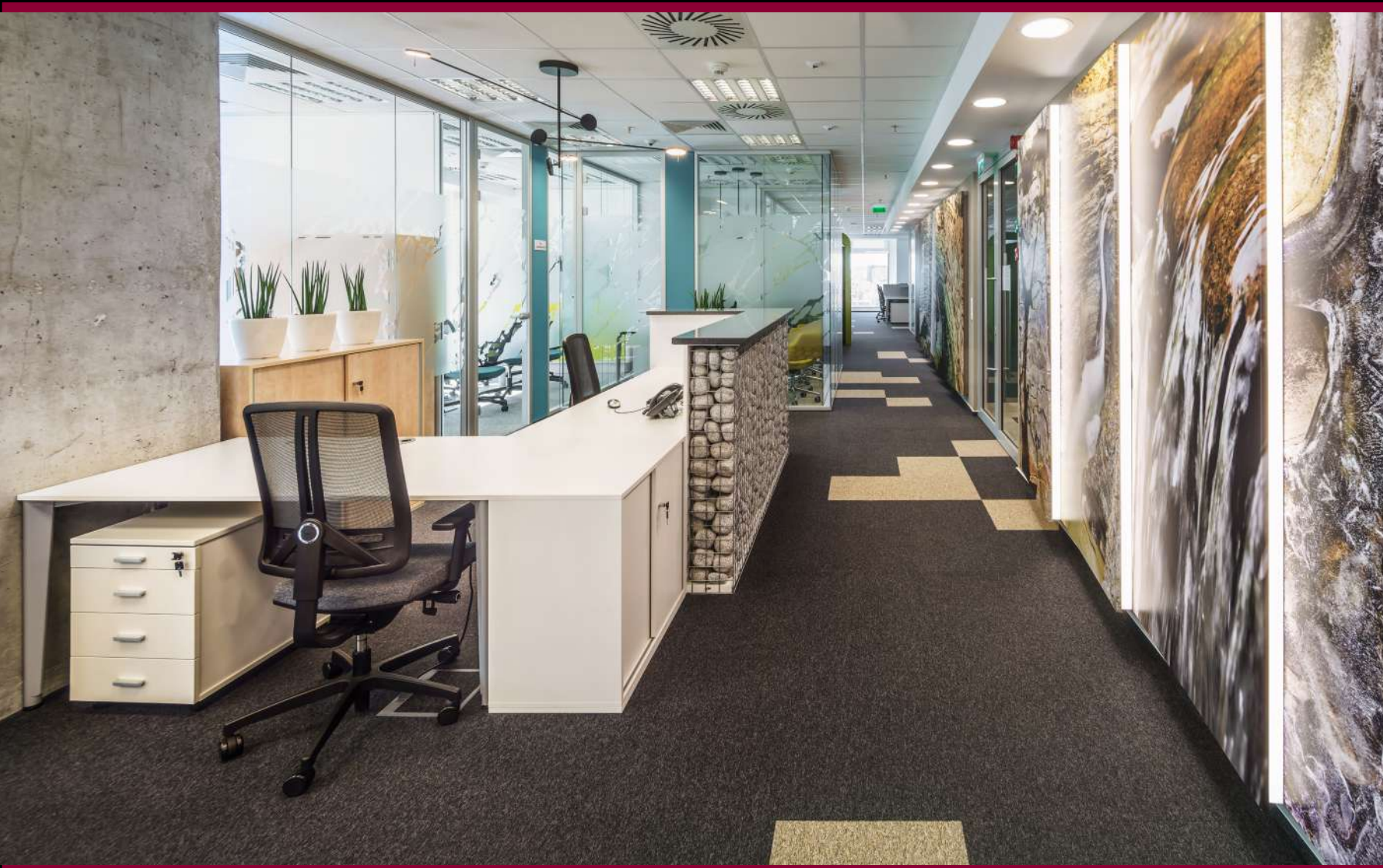

TASK CHAIRS

FLEXI



Modern office chair which meets high demands on functionality and design. The chair is equipped with synchronous mechanism ST1 to provide so-called dynamic sitting. Meshed backrest consists of a light-weight plastic frame with a central bracket with the advantage of height-adjustment within the range of up to 7 cm. In FLEXi collection, it is possible to choose from various types of upholstery, mechanisms and accessories for comfortable sitting.

Mechanism provides maximum comfort and ergonomics thanks to smooth run and optimum adaptation to any user. The seat and the backrest follow movements of the seated person, synchronously and at the correct angle, with the option of 5 lock-in positions. The mechanism's continual counter-pressure may be set within the range of approx. 45 – 135 kg of body weight.

FLEXI



Technical details

- » Synchronous mechanism with side and seat tilt adjustment
- » Height adjustable mesh backrest in black
- » Upholstered seat with depth adjustment
- » 5 star black plastic base on castors
- » Adjustable armrests covered with softened PU

Colors finish

- » Standard color finish: Black

Options

- » RAL 9006 or polished aluminum base
- » Gliders
- » Adjustable lumbar support
- » Headrest
- » Coat hanger
- » Gas unit with suspension
- » Plastic frame in white

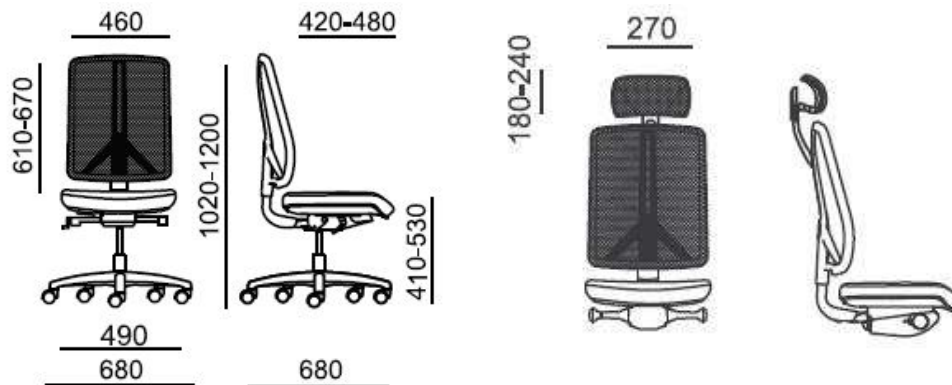

SIDIZ



Concentration is necessary for effective and productive office work. If, however, you are constantly distracted by back pain and other discomfort associated with poor seating then any desire to concentrate can transform into a superhuman effort. In such situation your best friend will be the modern Sidiz task chair. It provides you with such a degree of comfort that you forget about the world around you, which helps you achieve great results. However, you will have to live with the fact that at the end of your working day you won't want to leave your chair behind.

The chair has height-adjustable armrests, which can also be moved backwards and forwards, and synchronized backrest recline with adjustable tension thanks to which the chair suits everyone regardless of their figure. The seat can be positioned and angled, which ensures that the chair is suitable for all your activities, whether typing on a keyboard or viewing an important presentation.

SIDIZ



Technical details

- » Seat height: 435 – 525 mm (from ground)
- » Armrest height: 170 – 220 mm (from seat)
- » Backrest height: 970 – 1050 mm (from ground)
- » Weight: 16 kg
- » Suitable for users:
 - » Height: 150 - 190 cm
 - » Weight: 60 - 125 kg

Colors finish

- » Standard color finish: Black

Options

- » Polished Aluminium base
- » Conference version is also available
- » Headrest
- » Lumbar support
- » Seat covers are changeable and available in five color options

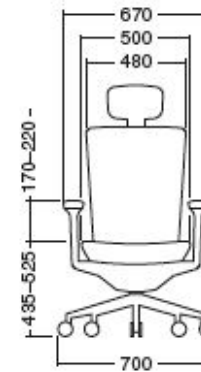

LIBERTY



The Liberty Task chair is an intelligent mesh task chair engineered to provide automatic lumbar support for every user, as well offering simplicity and complete ease of use. Liberty was designed to offer a unique, minimal aesthetic and to provide custom comfort for every person who sits in it. Liberty uses revolutionary Form-Sensing Mesh Technology and mechanism-free recline for perfect support and unprecedented comfort. With a minimal aesthetic that complements any space, the Liberty chair is the ideal seating solution for the modern work environment. With advanced features, including automatic, weight-sensitive recline, arm rests that are attached to the back of the chair for constant support and an innovative tri-panel mesh backrest, Liberty combines performance, simplicity and beauty. With fewer parts than traditional task chairs, Liberty is a timeless and environmentally friendly design.

LIBERTY

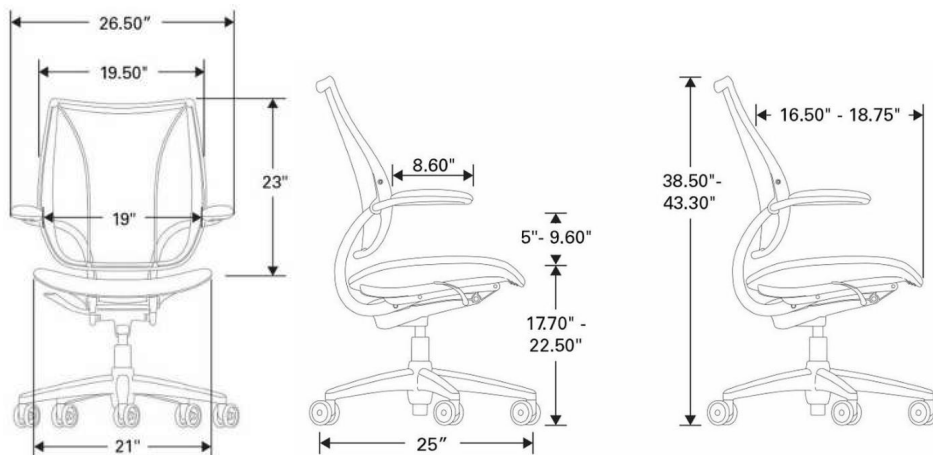

Technical details

- » Mesh backrest, Textile seat, Black/Silver frame, Fixed duron armrests
- » Chair Width: 67 cm Arms / 53 cm Armless
- » Seat Height Range: 42 – 87 cm
- » Recline Range: 18° recline + 8° backrest tilt

Options

- » Duron armrests – textile covered
- » Gel armrests
- » Adjustable option for armrests
- » Polished aluminum frame
- » Gel seat

Effortless Recline

- » Liberty's intelligent mechanism-free recline uses the laws of physics and the sitter's weight to automatically provide the perfect amount of support through the full range of recline. Without manual controls to adjust, the user can change postures effortlessly throughout the day.

Custom Fit

- » Liberty's mesh back is formed by combining three panels of non-stretch mesh material in the same way a tailor combines multiple pieces of fabric to create a shirt. Its contours are made to custom fit and support each individual sitter throughout the day.

Encourages Movement

- » Liberty was engineered to automatically adjust to whoever sits in it, instantly accommodating each user regardless of size and weight. Because it has no manual adjustments and features weight-sensitive recline, the user can move easily and without restrictions.

FREEDOM



Described by The New York Times as „the gold standard in office seating,“ the Freedom chair redefines the concept of traditional task chairs. Designer Niels Diffrient aimed to design an office chair that automatically adapts to the user, allowing them to move freely from posture to posture. Diffrient's unique approach removed complexities found in other chairs, such as cumbersome recline levers and back tension dials for a truly ergonomic task chair. As a result, he developed a recline mechanism that perfectly adjusts to the user, definitively reinventing modern task seating to be truly simple, functional and beautiful.

With innovative recline that provides constant support and a pivoting backrest that automatically adjusts to the needs of the spine, the Freedom chair is exceptionally comfortable and promotes movement throughout the day. Its refined and sculpted cushions were designed to mimic the body's natural contours and decrease pressure point loads for premium comfort.

FREEDOM

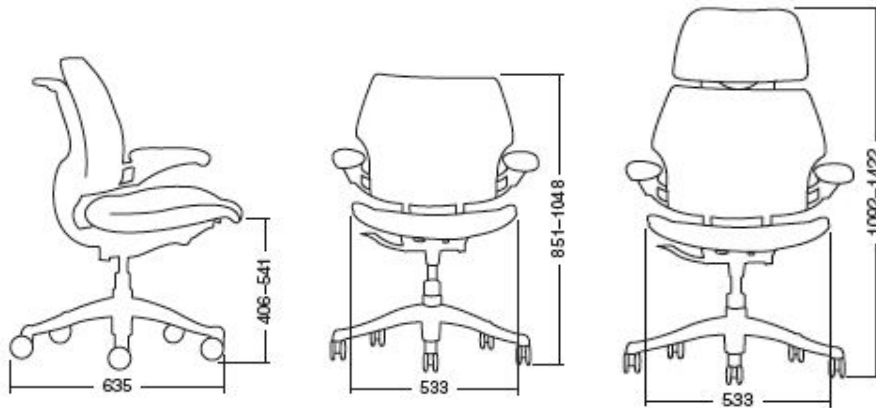

Technical details

- » Upholstered seat, backrest and headrest
- » Duron armrests
- » Graphite frame and base
- » Chair Width: 69 cm
- » Base Width: 63,5 cm
- » Height: up to 142 cm
- » Weight: 17 kg with arms / 15 kg without arms

Options

- » Duron armrests – textile covered
- » Gel armrests
- » Polished aluminum frame and base
- » Gel seat
- » Gliders

Articulating Headrest

- » The Freedom chair features a dynamic, articulating headrest to support the head and neck as users recline. It moves with the sitter, so they can change postures without making manual adjustments and stay comfortable in any position.

Self Adjusting Recline

- » Freedom eliminates the need for traditional recline mechanisms, which can be bulky and weigh up to 15 pounds. Instead, Freedom uses the sitter's body weight and the laws of physics to perfectly and automatically adjust recline support for each individual.

Synchronous Armrests

- » Freedom's body-friendly armrests move up and down together, staying with the user during recline for continuous comfort and support.
- » Unlike other chair designs, Freedom's armrests are attached to the back of the chair to ensure synchronous use.

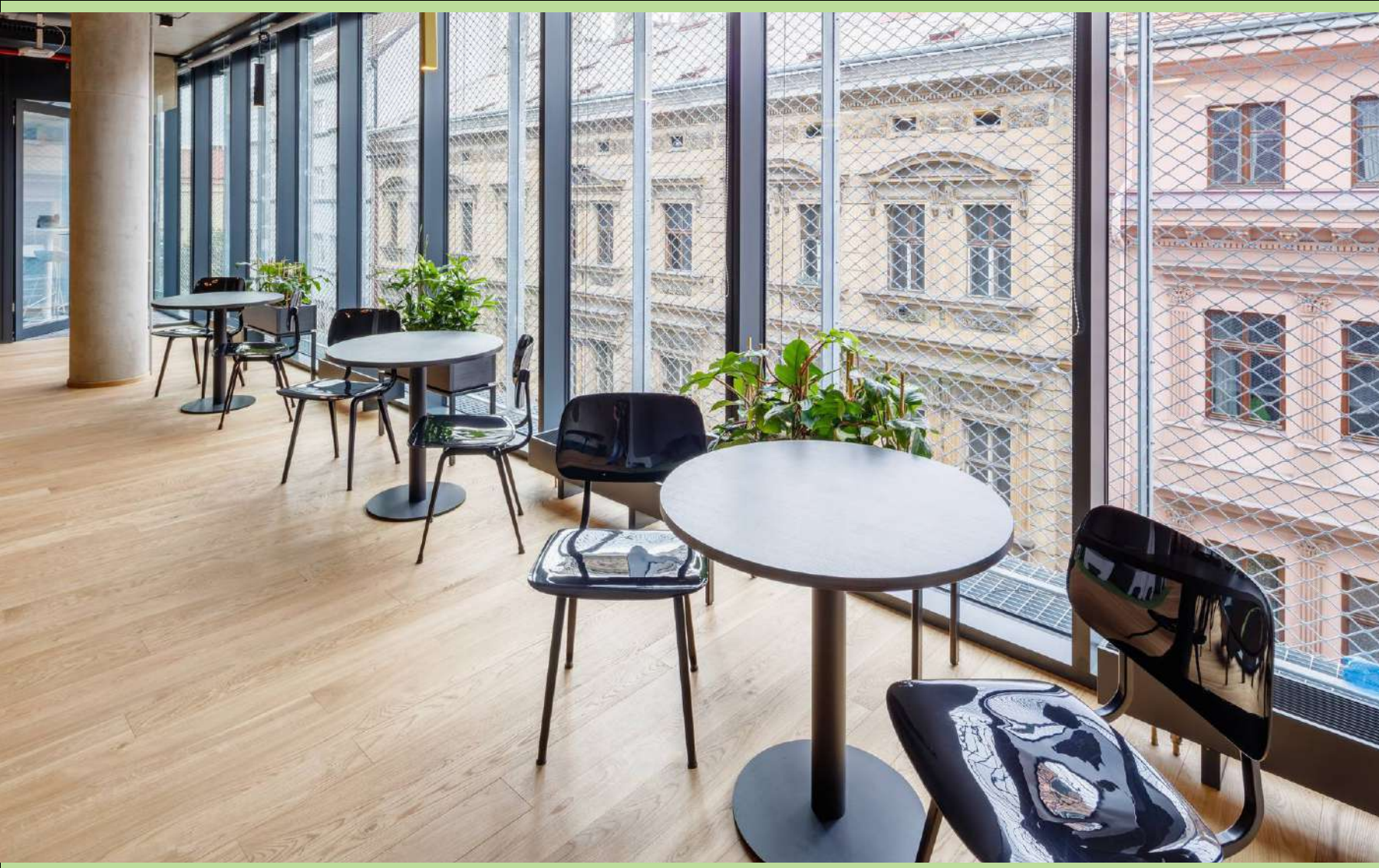

CONFERENCE CHAIRS

EVERYDAY



The Everyday chair designed by Paul Brooks, brings a perfect harmony of minimalist design, functionality, reliability and quality. Everyday is a superb seating option for contemporary interiors, for spaces that require modern yet comfortable seating as well as for spaces that require subtle design. With its superb quality and distinct look, the Everyday chair will enhance any interior.

Available in light grey, anthracite and black, the perfectly moulded shell is made of reinforced glass fiber nylon. The height adjustment control is integrated in the shell. A standard feature, the rocking mechanism is fully concealed in the bottom part of the shell.

EVERYDAY



Technical details:

- » Swivel, height adjustable
- » Light-weight plastic structure and fixed armrests made of black nylon
- » Relaxing rocking mechanism and pneumatic lift
- » Both seat and backrest upholstered with non stretch breathable black mesh

Materials and colors:

- » Nylon structure:
 - Black
 - Light grey
- » Seat and backrest:
 - Black/grey mesh
- » Mesh covered with fabric Omega, Theo nets or Rhythm
- » Base:
 - Black nylon 5 star base on castors
 - Light grey aluminum 5 star base on castors
 - Polished aluminum 4 star base on gliders

Options:

- » Black aluminum 5 star base
- » Polished aluminum 5 star base
- » Rubber castors for hard floors
- » Design rubber castors – suitable for both carpet and hard floor
- » Castors with chromed alloy body with black rubber wheels (for hard and soft floors)

FLEXI LOUNGE



The Flexi collection has been very well received at major international fairs Orgatec in Köln and Salone del Mobile di Milano where it was first introduced. Flexi seating excels at combining fresh design and unmatched comfort provided by superb ergonomics and flexible backrest in the conference models. Flexi is modern seating designed for modern times. Unique in the variability of its models, the collection will answer users' demand for various types of chairs of unified design.

An important qualitative feature in each model is the shell made of high-quality cold injected polyurethane foam. The system guarantees unchanging quality and appearance of the product during its entire lifetime.

FLEXI LOUNGE



Technical details:

Flexi XL:

- » Flexi XL with armrests/Flexi XL without armrests
- » Fully upholstered swivel armchair
- » High backrest
- » Polished aluminum 4 star base
- » Options:
 - Height adjustable 5 star base on castors
 - Relaxing rocking mechanism
 - Pillow seat
 - Footrest

Flexi L:

- » Fully upholstered swivel lounge armchair
- » Low backrest
- » Polished aluminum 4 star base
- » Design pillow (embroidery on demand)
- » Options:
 - Chrome-plated swivel circle base
 - Swivel side table – white HPL

Materials and colors:

- » Upholstered in all fabrics of categories E, F, M, O, COM+ a P

Base:

- » Polished aluminum 4 star base on gliders
- » Black powder-coated 4 star base on gliders
- » White powder-coated 4 star base on gliders

SIDIZ COMMUNICATION



People want special chairs in the space where critical matters are decided and valuable guests are served. The elegant lines of T50 conference series create the ambient yet more impressive feeling and enable to communicate lively.

Backrest comes in a smooth, curved frame that follows the spine's S-line. The Double Raschel material breathes well and stretches to provide comfort. The best ergonomics in chair means you are not aware of being seated while on the chair. Chair features making this possible with highly sophisticated adjustability and functionalities should free you of what disrupts your full immersion in the life. Having all of these features along with easy handlings, T50 series' high performance promise „the freedom your whole body enjoys“ at the moment of synchronizing yourself with the chair.

SIDIZ COMMUNICATION

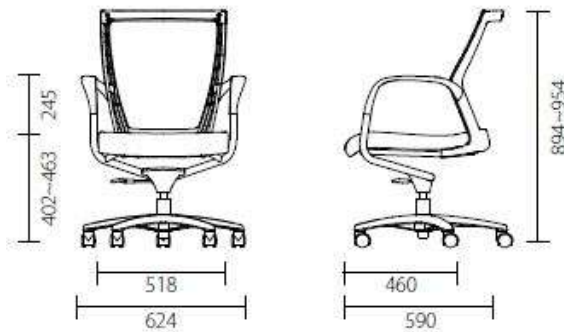

Technical details:

- » Swivel, height adjustable
- » Gas lift with auto return
- » Powder coated steel frame
- » Fixed plastic armrests
- » Mesh backrest
- » Upholstered seat

Materials and colors

- » Backrest
- » Black mesh
- » Upholstered seat – 5 fabric color options
- » Base:
 - Black plastic 5 star base on castors
 - Chrome 5 star base on castors

Options

- » Polished aluminum base
- » Nylon casters
- » Gliders
- » White plastic frame + elastic Double Raschel material (3 color options)

SIDIZ VISITOR



You want to have special chairs where valuable clients are welcomed or in rooms where critical decisions are made.

An impressive meeting room or visitors chair with slim harmonious lines. Features include a cantilever base combined with a high quality mesh backrest; uniquely curved armrests in plastic and a generous, well upholstered seat. Available from stock in Black with a powder coated steel frame.

Other colors or chromed frame are available to order.

SIDIZ VISITOR



Technical details

- » The SIDIZ conference chair has fixed plastic armrests, upholstered seat and mesh fabric backrest. The seat and armrests are rigidly attached to the steel base, which has plastic glides to protect the floor surface.
- » Chair weight 11 kg

Users characteristics

- » The chair suits over 90% of users:
 - Height from 150 cm to 200 cm
 - Body weight from 60 kg to 130 kg

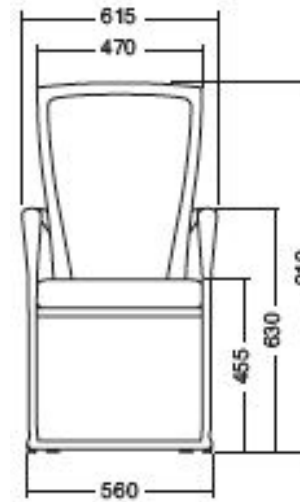

LANA



The best chair is one you are not even conscious of sitting on.

Lana is such a chair. A swivel chair for conference rooms and visitor seating. As designed by our regular collaborator, designer Hans Verboom, Lana will meet all requirements. It has an ergonomically shaped seat mounted on a four-arm polished aluminum base. This is made from a high-pressure casting, which ensures both durability and elegance. It also has aluminum armrests. With its glides, Lana can be used on all types of floor covering. In terms of fabric color we have been guided by the legendary Henry Ford – black is the color of choice.

The Lana chair may appear simple, but that is its greatest strength.

LANA



Technical details

- » Swivel conference chair
- » Seat from plywood, upholstered with padding and fabric (PVC artificial leather)
- » Armrests and base from polished aluminum
- » The legs are fitted with nylon glides
- » Weight 10 kg

User parameters

- » The chair suits over 90% of users:
 - Height from 150 cm to 190 cm
 - Body weight from 60 kg to 125 kg

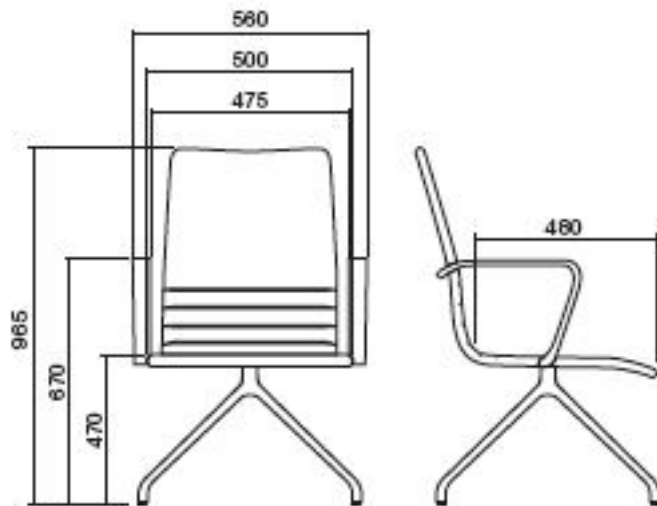

REVOLT



Many aspects of the Revolt were regarded as extremely innovative when it was introduced back in 1953 and it has won a permanent place for itself both in the business world and in Dutch living rooms. The Revolt chair is at home in every environment. After being discontinued for a number of years, Ahrend reintroduced the Revolt in 2004 . And once again, Ahrend has proved that a product that still has something to offer just gets better as the years go by. Revolt is available in black, white and in dust grey.

REVOLT



Technical details

- » Classic design dating back to 1953 and the designer Friso Kramer
- » Seat and back in high-quality high-gloss plastic
- » Tilting backrest
- » Glides for hard floors
- » Black, White and Grey
- » Height: 830 mm
- » Width: 470 mm
- » Depth: 510 mm

Options

- » Felt-tipped glides

DESIGNER - FRISO KRAMER

Friso Kramer was born in Amsterdam in 1922. After studying successively at the Montessori School, the Industrieschool and the Elektrotechnische School, he followed a course in interior architecture at the Instituut voor Kunstnijverheidsonderwijs (Institute for Education in Arts and Crafts) in Amsterdam.



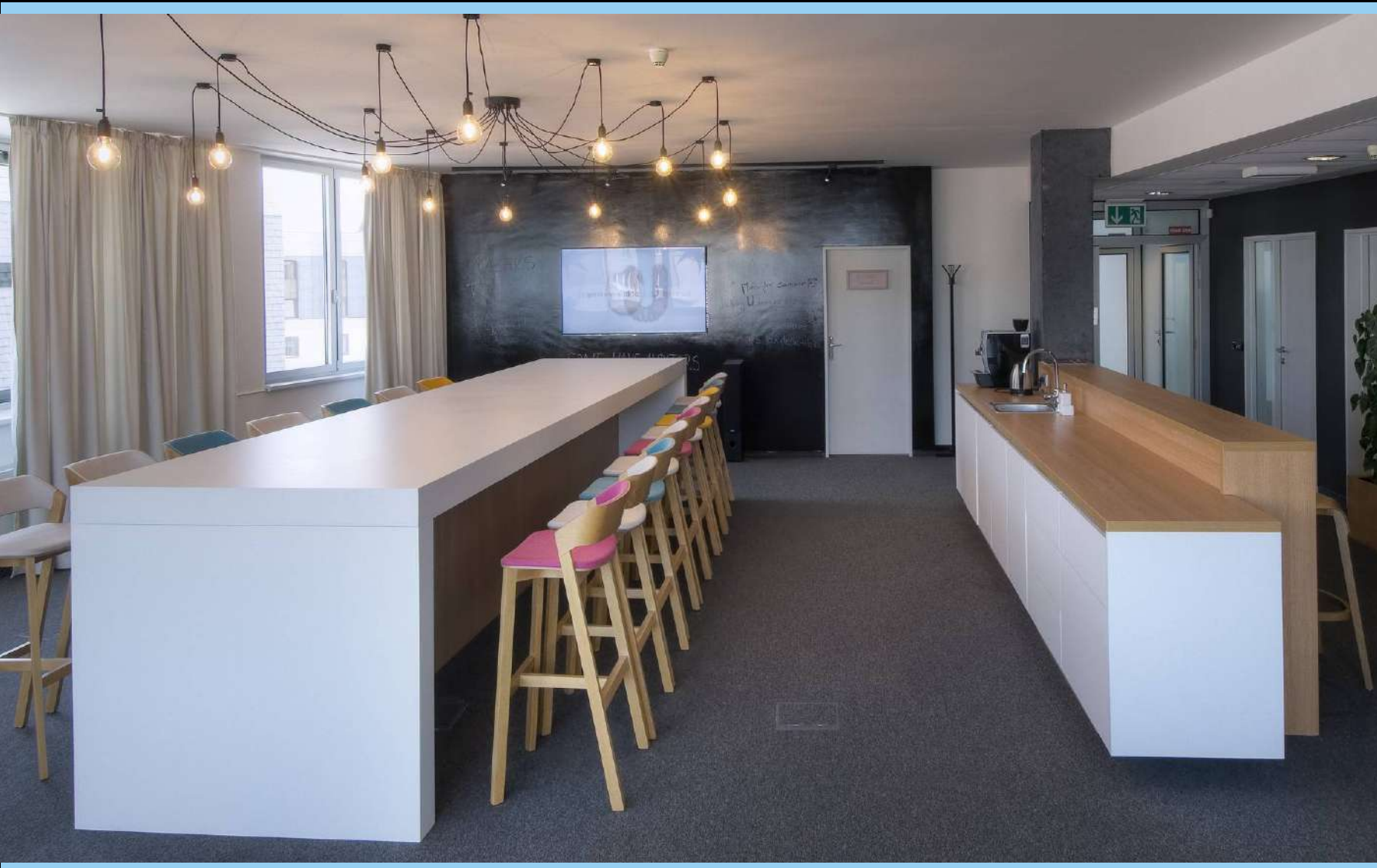

BAR STOOLS

RIOJA



The Rioja seat is named after the Spanish wine region. We offer a version of beech and oak which, thanks to its pattern, further highlights the elegant and fine shapes of this model.

RIOJA



Technical details

- » Two height options: Rioja 368 – h 640 mm, Rioja 369 – h 800 mm
- » Seat: 320 x 320 mm
- » Weight:
 - Rioja 368 – 6,23 kg
 - Rioja 369 – 7,14 kg

Decors and colors

- » Beech Standard
- » Beech Antique
- » Beech Pigment
- » Oak Standard
- » Oak Pigment



DESIGNER - LOUNGE DESIGNGROUP

This studio was set up in 2006 in the German city of Halle by Alexander Grimm and Ronny Eysser. They were involved in automotive projects for Fiat or Daimler-Chrysler and in the projects of well-known designer Luigi Colani. Lounge Designgroup currently offers design services and operates across many industries – in furniture production, lighting, wrapping materials, school items and interior design, merchandising items and corporate design.



MERANO



The Merano bar stool combines the bottom design made of solid wood with harmonic shapes of bent plywood in the seat and backrest. Thanks to the production technology used, it is remarkably light and does not contain any screws or metal pieces.

MERANO



Technical details

- » Frame in solid wood
- » Seat and backrest in bent plywood
- » Remarkable light, does not contain any screws or metal pieces
- » Upholstered version
- » Two height options:
 - Low barstool – h 824 mm
 - High barstool – h 994 mm
- » Seat:
 - 440 x 360 mm
- » Weight:
 - Low barstool – 6 kg
 - High barstool – 6,5 kg

Decors and colors

- » Beech Standard
- » Beech Antique
- » Beech Pigment
- » Oak Standard
- » Oak Pigment
- » American Walnut

PURE LOOP



Pure loop is synonymous with character, a choice that will perfectly fit in with the most sophisticated living areas and with bars and restaurants characterized by an informal or vintage style. Binuance type develops the colors, materials and technology of the Pure Loop family - the extremely elegant two-color one piece shell is obtained from a single polypropylene injection. All tone-sur-tone. The matt color combinations make these style suitable for countless applications and settings: casual, chic or total white.

PURE LOOP



Technical details

- Pure Loop, Pure Loop Binuance, Pure Loop Mini Dandy
- » Plastic seating shell and chromed metal frame and footrest
 - » Pure Loop and Binuance stackable
 - » Tube diameter: 20 mm
 - » Pure Loop and Pure Loop Binuance
 - » Height: 1105 mm
 - » Seat height: 760 mm
 - » Seat width: 550 mm
 - » Seat depth: 575 mm

Mini Dandy

- » Height: 940 mm
- » Seat height: 755 mm
- » Seat width: 440 mm
- » Seat depth: 485 mm

Materials and colors

- » Seat - plastic polypropylene
- » Frame - chromed metal

Options

- » Fully-upholstered shell
- » Fabric seat panel
- » Wood shell - beech/oak
- » Frame available in 2 heights: bar or kitchen

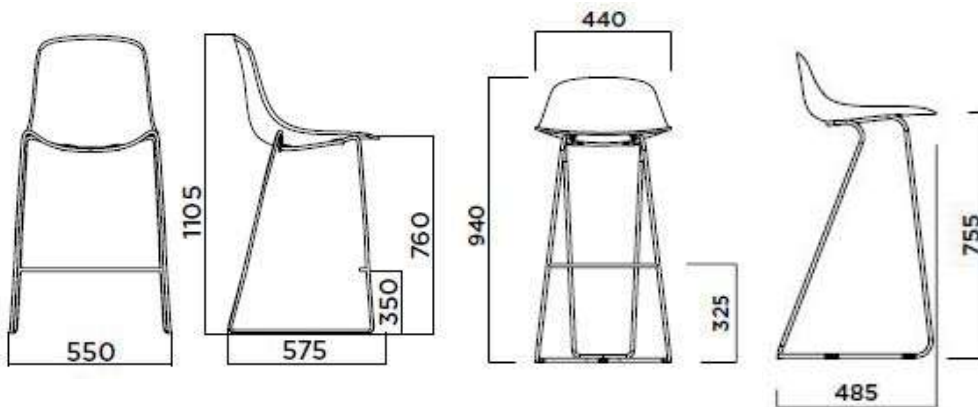

POPPY



Bars and high countertops are often lively and entertaining places where people are happy to meet. They are a fine place for refreshments and a relaxed space for informal discussion. However, the space would not be complete without the perfect bar stool. The Poppy collection offers two heights of the backrests and the possibility of upholstering the different segments of the chair. The subtle chrome frame fits perfectly into both modern and simple interiors. In addition to corporate relaxation zones, the Poppy is suitable for restaurants and in homes.

POPPY



Technical details

- » Stackable bar stool with high or low backrest
- » Chrome tubular frame with foot rest
- » Lacquered beech shell

Options

- » Upholstered seat or whole shell
- » Staining according to preference
- » High-pressure anti-scratch laminate coating of the beech shell from both sides.

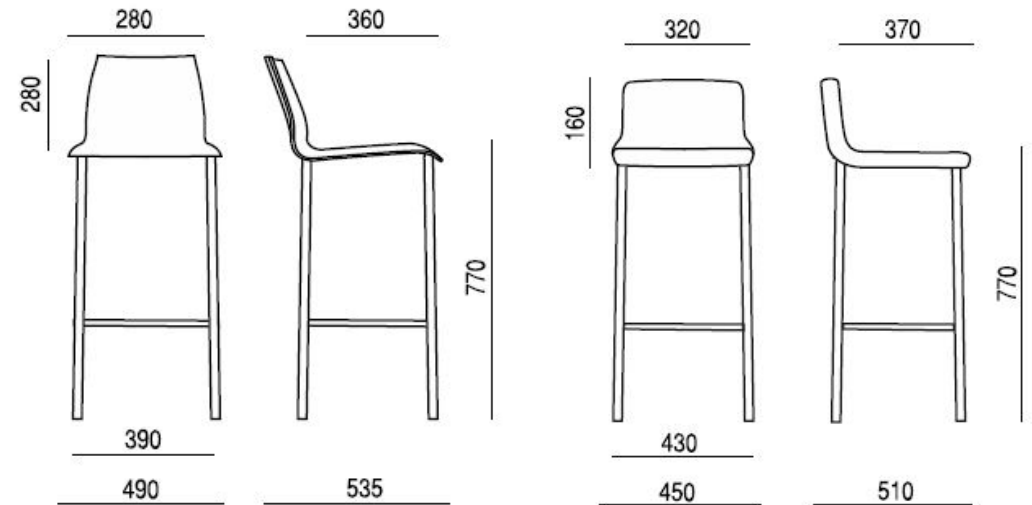

FLEXI HIGH



The FLEXi collection stands out for its functionality, perfect ergonomics and great design. Its wide range of features allows maximum customization for each user. Thanks to its innovative mechanism and intuitive operation, each feature's setting simplifies work and provides maximum seating comfort. The FLEXi was designed by Italian designer Massimo Costaglia and for its exceptionally successful design, it won the "Furniture of the Year" award in 2014.

FLEXI HIGH



Technical details

- » Swivel counter height chair with foot ring to height-adjustable tables
- » Black plastic frame
- » Black plastic 5 star base on castors, braked
- » Black mesh backrest
- » Upholstered seat
- » Fixed black plastic armrests

Options

- » White plastic frame
- » Chrome frame
- » RAL 9006 silver frame
- » White plastic base
- » Polished aluminum base
- » RAL 9006 silver base
- » Grey/white mesh backrest
- » Gliders





CAFETERIA CHAIRS

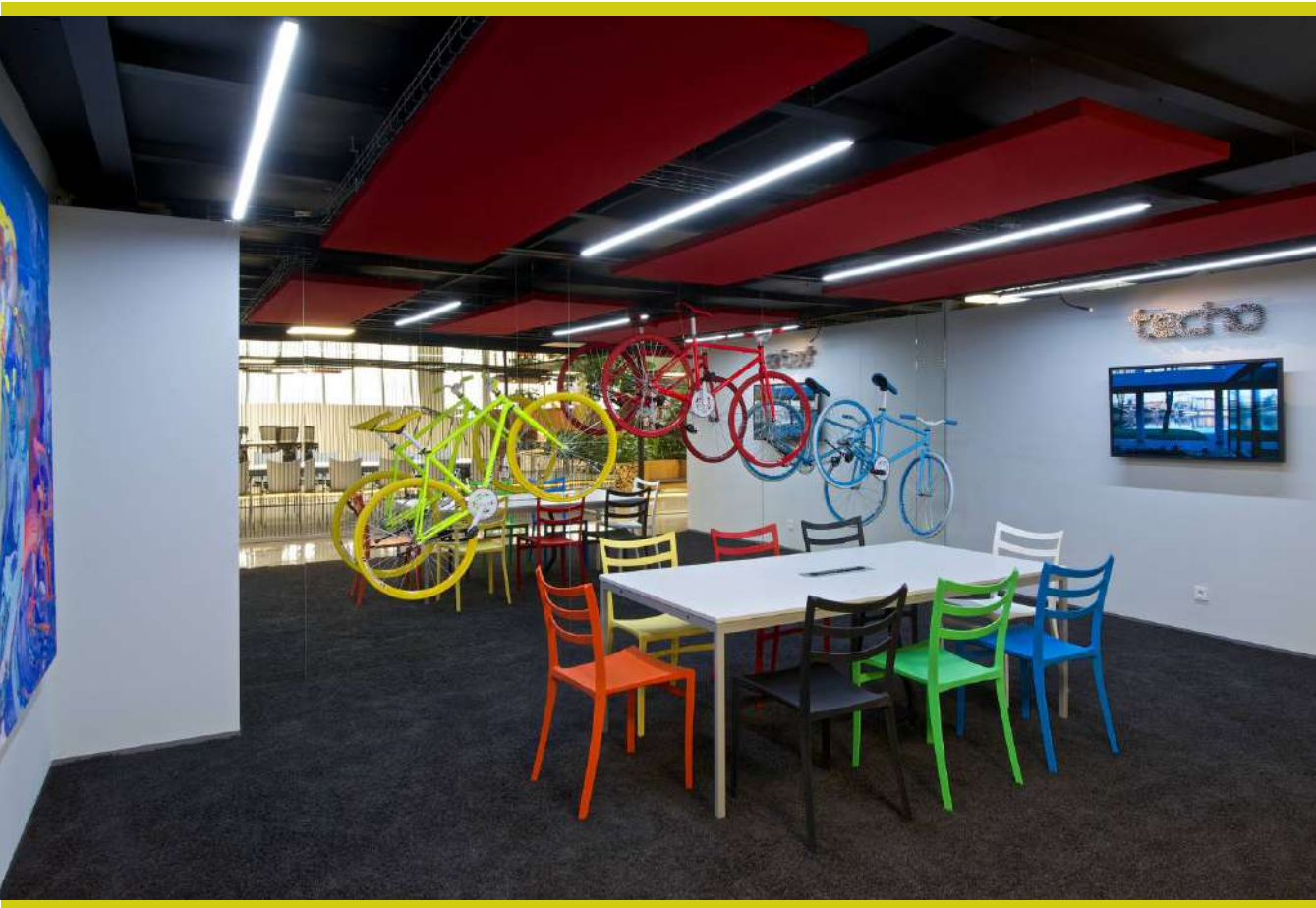

The FLEXi collection stands out for its functionality, perfect ergonomics and great design. Its wide range of features allows maximum customization for each user. Thanks to its innovative mechanism and intuitive operation, each feature's setting simplifies work and provides maximum seating comfort. The FLEXi was designed by Italian designer Massimo Costaglia and for its exceptionally successful design, it won the "Furniture of the Year" award in 2014.

Technical details

- » Vacuum moulded ABS reinforced with glass fibers
- » Strong and light – wear resistant with long service life
- » Stackable up to 10 pcs
- » Weight: 3,45 kg
- » Maximum load: 120 kg
- » Colors:
 - RAL 9010 White
 - RAL 9004 Black

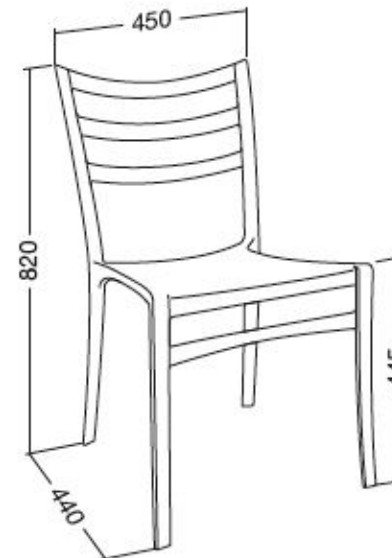

WEB



The web is a stackable line of chairs which features elegant Italian design. Its applicability is truly multi-functional. It can be used in meeting rooms, in cultural halls, lobbies, and in libraries and schools. The collection includes bar chairs so it is also acceptable for cafes and canteens. It is able to adapt to many spaces due to several variations of plastic colors, seat upholstery and backrests or the use of mesh. Thanks to its slender construction, the Web makes a subtle and soft impression. The Web is ideal for places that often change their seating layout according to the event or the number of participants.

WEB



Technical details

- » All plastic chair on a thin high-strength wire frame
- » Black/White plastic shell
- » Plastic gliders
- » Stackable up to 45 pcs

Options

- » Armrests
- » Bar height version available
- » Plastic shell colors: blue, green, grey, red, sand
- » Writing table – left/right, black/white
- » Plastic connectors for connecting into rows
- » Cut out handle in backrest
- » Transport trolley

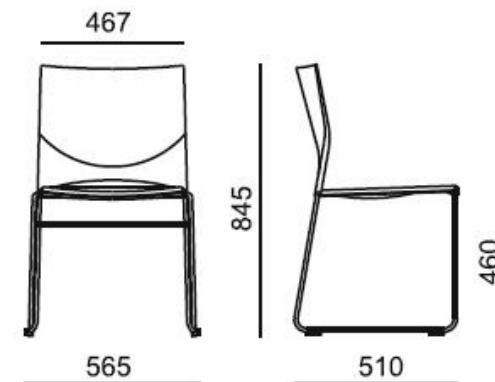



ACOUSTICS

WF25_ DESK SCREEN



In addition to design and functionality, TECHO office furniture can also exhibit privacy and snugness – a fine example of this is the versatile WF25 screen system. This frameless screen system is able to improve the quality of the workplace environment, improve the acoustic conditions and also have a significant aesthetic impact.

The screens have a chipboard or fiberboard core that is covered with a fabric of your choice from the BLAZER LITE or BOMBAY fabric ranges. The screen is attached to the desk using holders, or there is also a freestanding option. In addition to the above options we also offer a pinnable version.

WF25

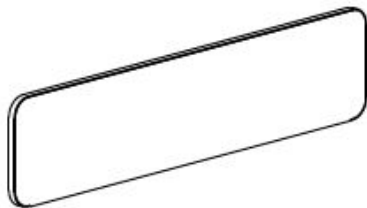

Technical details

- » Max. dimensions for MD screens (attached to desktop):
 - Height: 500 mm
 - Width: 2000 mm
- » Max. dimensions for V screens (freestanding):
 - Height: 1750 mm
 - Width: 700 mm

Colors

- » BLAZER LITE (100% wool) and BOMBAY (100% polyester) fabric ranges

Options

- » Dimensions according to desk size
- » Wide range of color finishes
- » Freestanding, attachment to desktop with holders
- » Pinnable version
- » A wide range of accessories, such as suspended boxes, and holders for pens or note paper

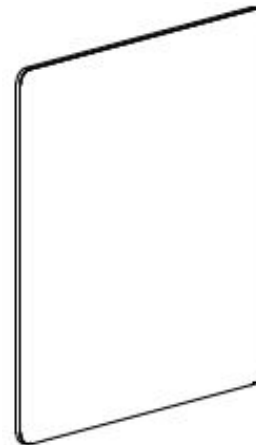

SONIC_DESK SCREEN

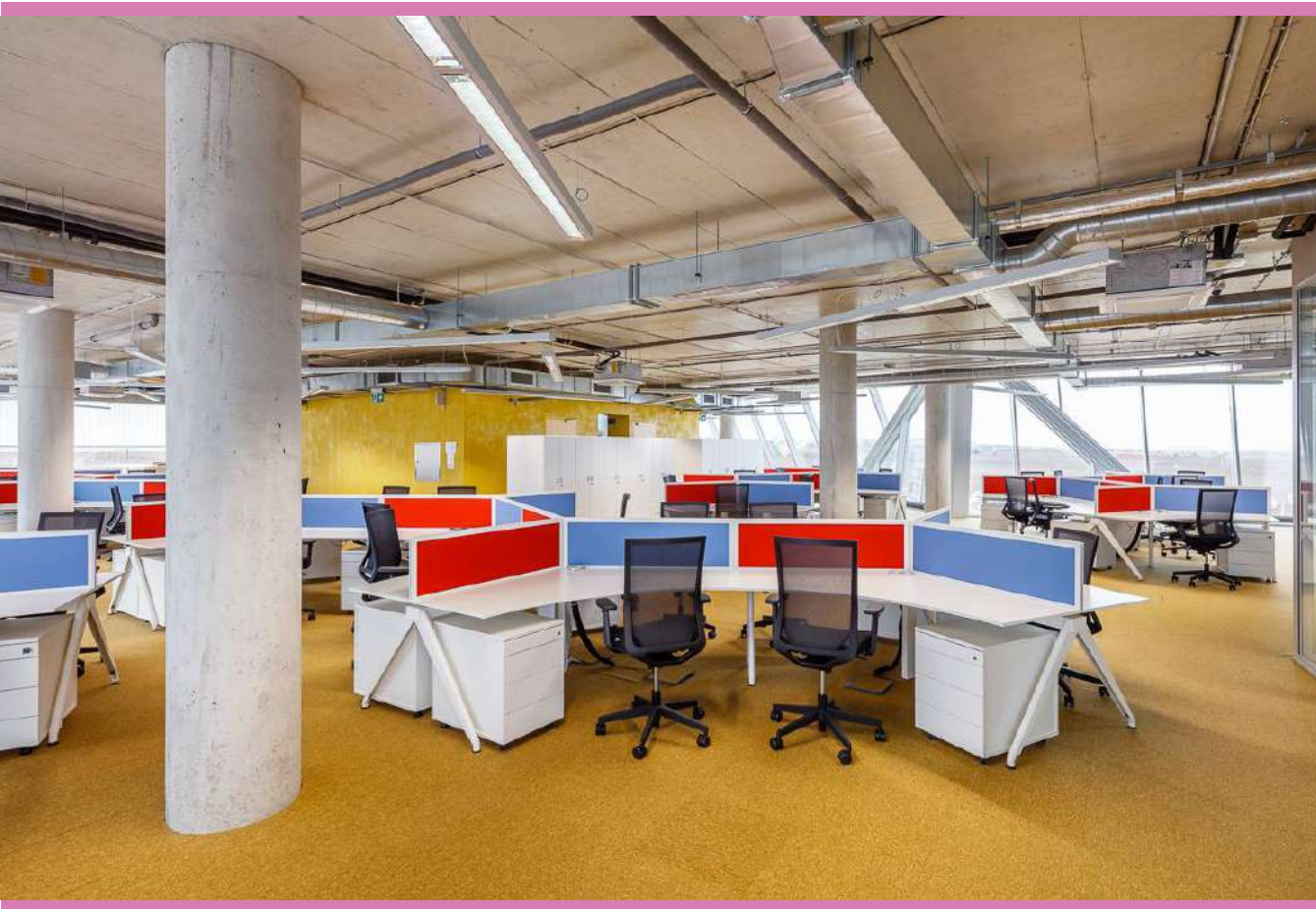

70% of office workers state that their work would be more productive in a less noisy environment. Sonic acoustic screens contribute to the creation of a comfortable and productive working environment. They help to reduce the transmission of sound from one workstation to another, and thus limit unwanted distractions. The Sonic screens have been designed using advanced acoustic material from BASF - Basotect®. The high sound absorbency and fire resistance make Basotect® ideal for use in furniture applications. The Sonic acoustic screens create a comfortable work and relaxation environment and the low-key design enables interior architects to concentrate on the aesthetics of the space without restrictions.

These screens have been designed to improve the workplace environment. In open-plan offices they provide a degree of privacy and enable concentration on the work in hand. They also help to reduce noise distraction. By attaching office accessories worksurface efficiency and clarity can be increased.



Technical details

- » The screen has a sound absorbing filling and a frame 51.4 mm thick made from aluminum profiles with the option of fixing the screens to desk configurations, of attaching accessories and of connecting several screens together.
- » The core material is chipboard based and 8 mm thick, which provides the necessary rigidity and stability.
- » On both sides of this core panel is adhered 20 mm thick acoustic damping foam, which is categorized as „difficult to ignite“ and in accordance with standard EN 13501-01 it is classified „B, s1, D0“.
- » Thanks to its unique properties it is used in the aerospace industry and for insulating buildings and trains. As sound insulation it is used in cinemas, test facilities and concert halls etc.
- » The foam is covered with a fabric that is fastened to the aluminum profiles that frame the screen assembly.
- » The outer frame profiles have corners from aluminum castings and plastic covers

Colors and fabrics

- » Standard color finishes for metal and plastic parts
 - RAL9022 – silver
 - RAL9010 – white
 - RAL9004 – black
- Metal profiles have a powder-paint finish.

Fabric for screens: LUCIA

- » 100% polyester, 270 g/m²
- » Abrasion resistance BS476 50000
- » Martindale pilling resistance 4+
- » colorfastness 6+

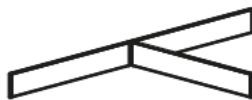

DIVERSE_ FREESTANDING SCREEN



Diverse screens draw on inspiration from the London underground tube map. The CNC stitched grooves cross each other in an orderly fashion.

Screens are often reliant on the pattern of a fabric and are covered to enhance its presence. With Diverse, a visually appealing graphic solution was added with screens that enhanced the new product, allowing the breakup of larger corporate spaces or seating areas.

In a constantly changing and evolving workplace, it's critical to create privacy by screening. For spontaneous team meetings or confidential conversations, this modern screen gives enough protection from the environment. Diverse can be placed freely in the lounge or open office areas. Thus, this partition will define clearly delimited areas without ever closing itself completely towards its surroundings.

DIVERSE



Technical details

- » Height: 1650 mm
- » Width: 1200 mm

Colors and fabrics

- » Chrome legs
- » Screen body available in six categories of upholstery fabrics

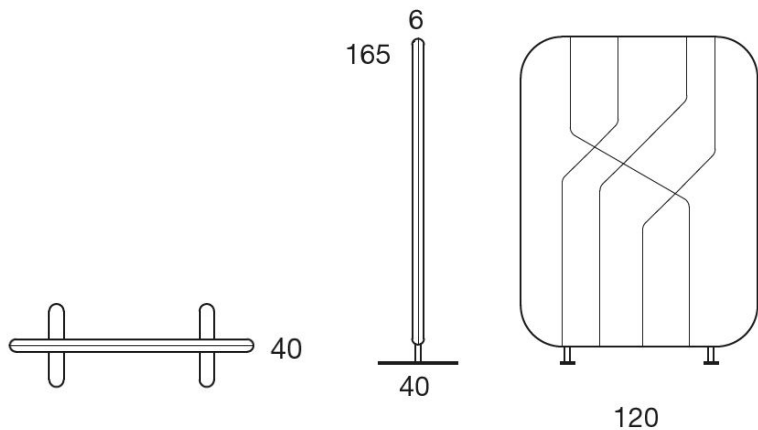

DESIGNER DAVID FOX

David Fox Design is a UK based Industrial and Product design consultancy. Since establishing the business in 2002, David has worked with an international client list, and has won many prestigious design awards. His philosophy and work ethic promote elegance and refinement. His well balanced, innovatively detailed, simplistic forms give his work a timeless aesthetic.



SHADE_FREESTANDING SCREEN



70% of office workers state that their work would be more productive in a less noisy environment. Sonic acoustic screens contribute to the creation of a comfortable and productive working environment. They help to reduce the transmission of sound from one workstation to another, and thus limit unwanted distractions. The Sonic screens have been designed using advanced acoustic material from BASF - Basotect®. The high sound absorbency and fire resistance make Basotect® ideal for use in furniture applications. The Sonic acoustic screens create a comfortable work and relaxation environment and the low-key design enables interior architects to concentrate on the aesthetics of the space without restrictions. These screens have been designed to improve the workplace environment. In open-plan offices they provide a degree of privacy and enable concentration on the work in hand. They also help to reduce noise distraction. By attaching office accessories worksurface efficiency and clarity can be increased.

SHADE



Technical details

- » Standard height: 1200, 1500 and 1800 mm*
- » Standard width: up to 1500 mm
- » Central supporting plate lined with sound-absorbing foam

Colors and fabrics

- » Decorative fabrics:
 - available in 6 categories of upholstery
- » Legs:
 - Wooden
 - Coated steel – attached externally/internally

Options

- » Customization, fabric printing
- » Non-standard shapes

*configurations with height greater than 1500 mm only available with coated steel feet, attached externally

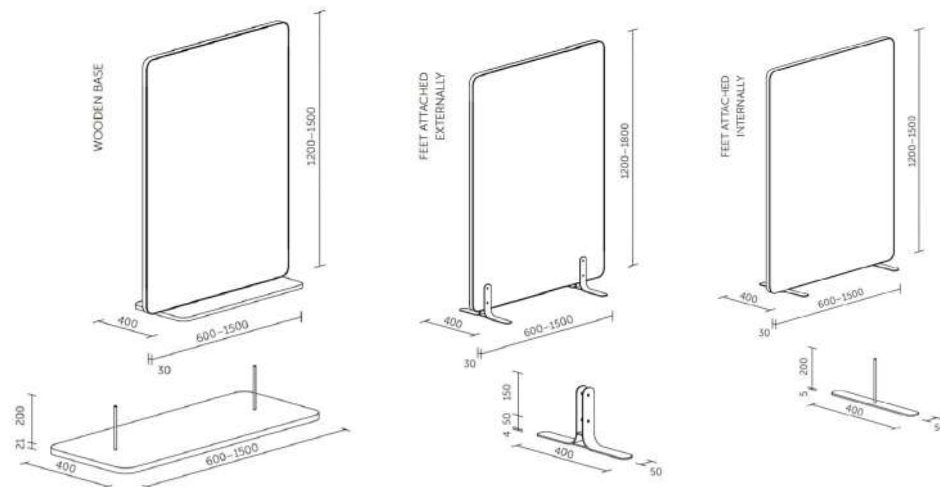

FLEXI_ FREESTANDING SCREEN



Flexi gives you the perfect weapon in the fight against noise in open-space offices and elsewhere. These blinds have excellent acoustic properties and you can position the panels to close off or reveal as much of the workspace as you desire. You can also move them around the office as needed.

FLEXI



Technical details

- » 1530 x 400 x 1565 mm
- » Possible to regulate how open the space should be by adjusting the panels

Colors and fabrics

- » Decorative fabrics:
available in 6 categories of upholstery
- » Support plate:
Oiled plywood
Black painted sheet metal

Options

- » Customization, fabric printing

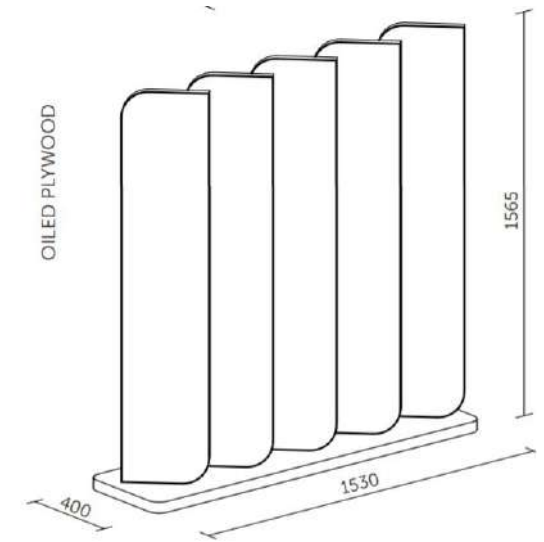
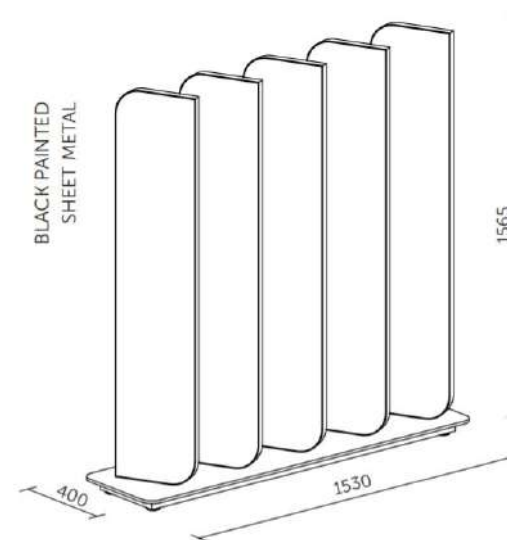

WALL AND CEILING PANELS



Wall and ceiling panels improve acoustics and their various designs make them a feature in any room. The panels can be varied to form different patterns in different colors, with or without textile. Core is made of unique material EcoSUND. This core material is available in three colors, and with the possibility of laminating with several different textiles, your wall/ceiling becomes almost unique. The thickness of the absorber varies for each style.

WALL AND CEILING PANELS

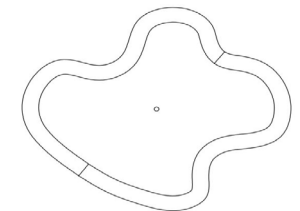
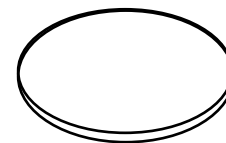
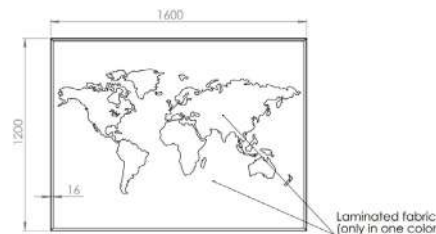
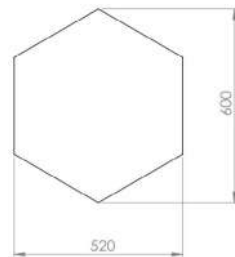
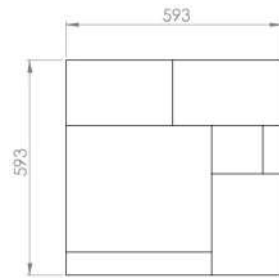

Technical details

- » Raw panels/ panels dressed in fabric
- » Variety of thicknesses for panels

Decors and colors

- » Raw EcoSUND panels in white/black/grey
- » Dressed panels – variety of fabrics and colors

» NIVA

593 x 593 mm, Thickness: 90 mm

» HONEY

600 x 520 mm, Thickness: 20, 40, 50 mm

» WORLD MAP

1600 x 1200 mm

Frame: white, black

» SOUND OFF

Ceiling panels can have optional LED light

Circular:

Dia 800, 1100, 1400 mm, Thickness: 50 mm

Square:

600 x 600, 800 x 800, 1000 x 1000 mm

Rectangular:

600 x 800, 600 x 1000, 600 x 1200, 1000 x 1200 mm

» HANG OVER

598 x 105 mm

810 x 130 mm

CARA HIGH



Cara Highline provides a privacy solution for open areas. You can be in the lounge space, but you can still feel alone and comfortable while checking you mails or making a call. With its medium and high options, Highline is a perfect and comfy solution. Make your meetings on the pod table, welcome your guests being isolated from the rest of the surrounding.

CARA HIGH

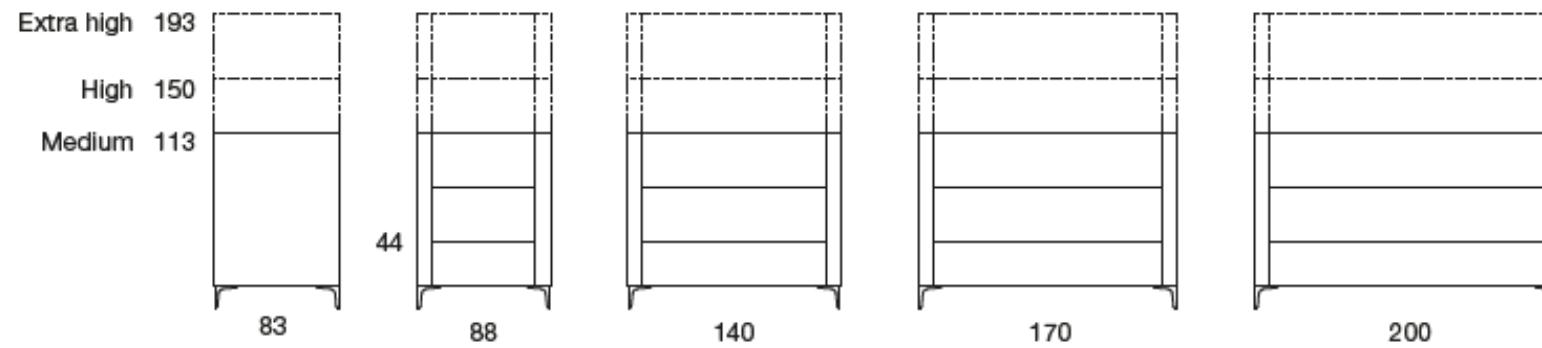

VERSIS



The design approach of Versis was seen as a conceptual relaxing and privacy zone in an open space. The two different heights let you choose your privacy level. You can be hidden while you rest your hands on the armrest of our sofa. Isolate yourself, be in and out of the lounge, and divide the space. Thin plywood arms of Versis are designed to reduce the bulk of the height. Tubular arm-like bent metal bases can not only create bulk reduction, but also help keep the floor clean considering the size of the sofa. The inner space of the sofa helps travelers who always need meetings in public settings. The concept of Versis allows different combinations of upholstery and color schemes in the same sofa. This privacy promising sofa welcomes you with medium and high versions and is a key piece for restaurants or office environment. All around closed boxes or 2 sides open boxes are offered alternatively. Versis legs can be chromed or powder coated.

VERSIS

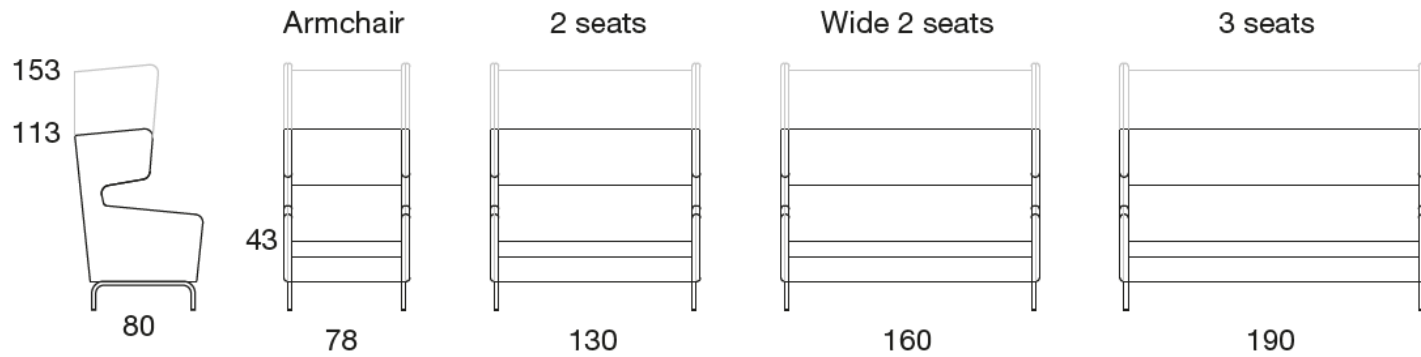

THE HUT



Creating natural meeting places in large open spaces that today's offices often are made of, is one of the strengths with the room-within-a-room concept. The Hut Collection contributes with a dynamic feeling and an eye-catching detail, all while the screened off spaces generate creative condition and improve acoustics for everyone.

The house's simple and straight lines are inspired by the classic game of Monopoly and its game pieces that give a timeless shape to the popular and practical "room-in-room" concept. The house can be used for several purposes; as an individual workstation, a small sit-and-stand meeting room or as relax areas.

THE HUT



General

- » Room-in-room concept available in regular size The Hut and smaller version Half The Hut

Options/Configurations

- » The Hut Sofa
- » The Hut Sofa with table top – white/black/silver (includes 2x2 power outlets mounted in the sofa)
- » The Hut with front screens
- » The Hut with front screens and plexi door
- » Cable channel mounted in the Hut
- » The Hut Lamp
- » Magnetic Whiteboard

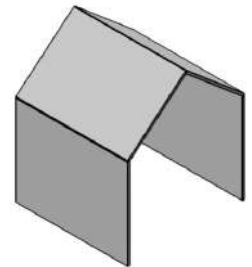
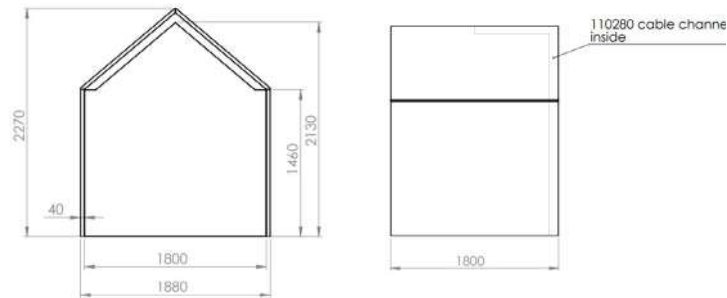
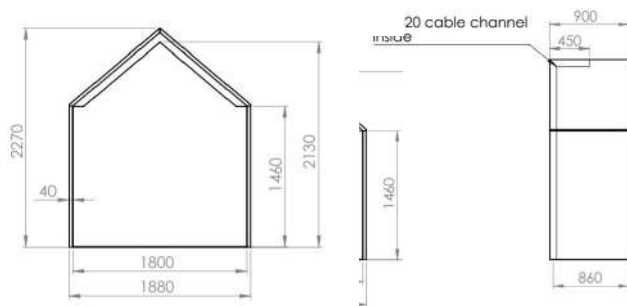
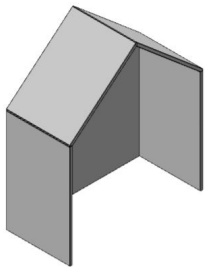

THE PLANET



The Planet is a creative approach to the boundaries of your personal space, a totally new level of comfort work in the office. It is an innovative solution for co-working and open-spaces. It brings together minimalism and comfort in an eye-catching and clever design. Ideal for both residential and commercial spaces. The Planet can substitute the personal office and even a personal relax zone. It is great for the moments when you need to stay alone, gather your thoughts and focus attention on the task, take your mind off the office bustle, switch yourself and have a cup of coffee alone. An ergonomic mattress and such additional conveniences as a storage pocket, led-lamp - make The Planet a true stand-alone station for work and leisure.

THE PLANET



Technical details

- » High-quality plywood, covered with a protective layer of oil-wax, metal
- » Possible to use indoor/outdoor
- » Fabric mattress with filler
- » LED lamp

Options

- » 4 metal covers with the special surface to write
- » 2 plywood covers with the special surface to write
- » Set of 3 markers
- » Set of magnets
- » Moss as décor
- » Storage pocket
- » USB charging
- » Speaker system
- » Solar panels



SILENCE CALL



Our work environment is rapidly changing. With open-plan offices, co-working spaces and multimedia, we are more connected than ever. At the same time we are more distracted, stressed and burned-out than ever. We're surrounded by noise. All the time. The Silence CALL is the perfect solution for Activity Based Working. The completely secluded and acoustic space-in-space subdues sound up until 47 dB and is a functional and sound absorbing solution for making phone calls or working concentrated, while being in a modern and open space office. It's time to make a call for silence.

SILENCE CALL



Technical details

- » Creates a space-in-space
- » Extremely easy to assemble and disassemble on-site
- » Fulfills an acoustic purpose both in and outside the box
- » 100% Plug & Play: electrification and ventilation come as a standard

- » Sensor that switches on and off the light and ventilation automatically
- » Integrated wheels for easy transport
- » Ergonomically designed table to put devices on
- » Indirect ventilation providing a very comfortable air flow
- » Subdues sound up to 47 decibel

Outside

- » W 98,8 cm x D 99,7 cm x H 225,0 cm

Inside

- » W 81,5 cm x D 89,0 cm x H 203,0 cm

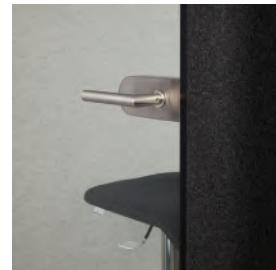

Options

- » Table finish: oak, white, black
- » Height adjustable and turnable stool for more comfort
- » Outside available in the fabrics Divina, Divina MD and Divina Melange, made from sustainable materials

MICROOFFICE



MICROOFFICE is an ode to minimalism in the shape of an independent workspace. It is the bridge between the two halves of its environment, creating a private and peaceful inner world in the center of the chaos around it. These two realms are linked through vision, energy, light and sensation.

MICROOFFICE captures an insulated bubble of peace without the burden of difficult installation or renovation. New iconic design features a unique ventilation system, high-end acoustic materials and even more sophisticated details than before.

UNIQ, QUBIC, QUADRIO



Technical details

- » Glass walls: sound-insulating glass
- » Solid walls: sound-absorbing sandwich panel with acoustic insulation
- » Ventilation: automatic/manual
- » Lighting: LED/design lamp
- » Equipment: desk, seat, electric socket, USB and LAN connection
- » Flooring: carpet

Options

» UNIQ – 1 person

Exterior dimensions: 1200 x 1000 x 2320 mm
Interior dimensions: 950 x 930 x 2150 mm

» QUBIC – 2-4 persons

Exterior dimensions: 1780 x 1500 x 2270 mm
Interior dimensions: 1500 x 1470 x 2100 mm

» QUADRIO – modular meeting room which can grow in size by adding more panels

» Exterior dimensions: 2520 x 2856 x 2300 mm
» Interior dimensions: 2245 x 2766 x 2150 mm

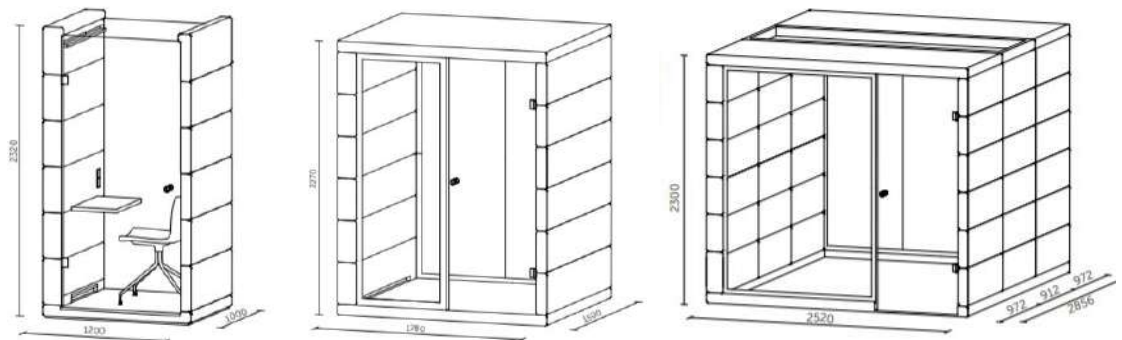



STORAGE SPACES

CABINETS



You have already furnished your office with a high-quality desk and chairs, but there is a lack of space for filing important documents? TECHO has the answer for you – wooden cabinets. We supply them in the same color/décor finish as the office desks and conference tables. You can therefore be sure they will suit the rest of your office.

During the design process we devoted special attention to the doors to ensure maximum access to the storage space. The first option with sliding door is ideal particularly for small spaces. The edges of the doors are fitted with a plastic dust shield that prevents dust getting into the cabinet, and it also dampens noise when opening and closing. The second option, a cabinet with wing doors, requires more surrounding space, but the doors open to an angle of 110°, thanks to which it is very easy to access the storage space. Another option is a tambour door, which allows maximum use of the storage space. Open cabinets (without doors) are also available in all height versions, which increase variability when creating storage walls.

CABINETS

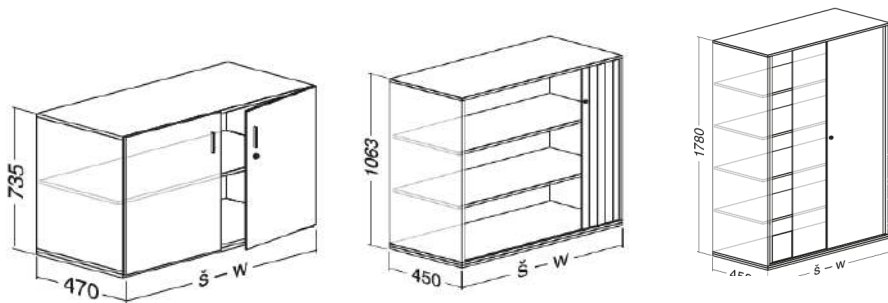

Technical details

- » Material: MFC, laminated chipboard
- » Thickness: 8mm (the back) and 18 mm (the rest of the cabinet)
- » Edge 1mm (carcass) and 2mm (door)
- » Cabinet dimensions:
 - » Height options: 735 mm / 1063 mm / 1780 mm
 - » Width: 800 mm / 1000 mm / 1200 mm
 - » Height of metal plinth: 18 mm
 - » Cabinet depth: 450 mm
- » It is possible to fit MFC shelves with AL profiles with a load capacity of 30 kg
- » All cabinets are fitted as standard with a lock.

Decors and colors

- » Carcass and doors:
 - We offer a wide range of decors from suppliers Egger, Pfleiderer and Kronospan.
- » Pull-out elements, frames, plinth:
 - Black
 - Gunmetal
 - White
 - Anodised natural
- » Tambour:
 - Silver

Options

- » Versions available with sliding and wing, and tambour doors, as well as open cabinets
- » Various option
- » A wide range of internal fittings are available, such as fixed shelves, frames, pull-out shelves, pull-out frames and wardrobe shelves
- » Visible fabric back board

MFC PEDESTALS



Good work requires full concentration, which is difficult to achieve if you are constantly distracted by piles of paper and office stationery on your desk. The new generation of TECHO pedestals are available with three levels of user comfort in terms of the type of drawer runners fitted. Our range covers the requirements of customers from those who place emphasis on a low price to those willing to pay more for comfort and convenience at work.

Pedestals are available in three versions depending on the type of drawer runner used. The pedestals can also differ in terms of number and size of drawers and width of carcass. In all cases the drawers can be extended to 75% of their depth. In addition, all the pedestals are fitted with a lock system incorporating an anti-tip mechanism. This centrally locks and unlocks all drawers and only permits one drawer to be extended at a time. They can be divided into several smaller sections using dividing partitions.

MFC PEDESTALS



Technical details

- » Material Carcass and drawer fronts: MFC
- » MFC thickness: 18 mm
- » Drawers: metal
- » Components:

Type C - drawers, runners, locking bar and file holders from global sourcing

Type B - drawers with damping (system TOP 2000), runners, locking bar and file holders from HETTICH

Type A - drawers incl. top drawer with damping and self-close (system TOP 2000), runners, locking bar and file holders from HETTICH

Decors and colors

- » We offer a wide range of decors from suppliers Egger, Pfleiderer and Kronospan.

Options

- » Mobile and desk-high
- » Internal drawers dividers available as an option
- » Textile seat can be incorporated on pedestal top

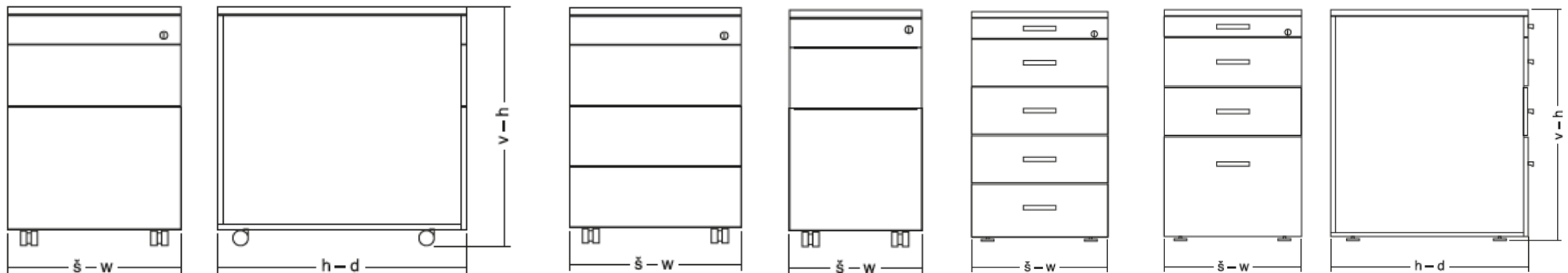

LOCKERS



This innovative storage system is intended for office buildings, sports centers and schools. The Smart Lockers are made from MFC and metal. They can be ordered in standard dimensions or can be produced bespoke. The cabinets are connected into configurations and finished with side panels. This creates a unified wall. Several versions of electric lock are available and allow users to control lockers using their own RFID cards or a mobile phone application. Advanced software enables the convenient remote management of all lockers. The electronic locks meet the strictest criteria for placement in public places, including a safety certificate and the ability to open all lockers at once. Smart Lockers are intended for storing the personal belongings of employees in office buildings, or visitors to sports centers. The lockers are fitted with an electronic lock that enables them to be opened using, for example, a RFID card. The locks can be set in several modes depending on the requirements of the operator.

LOCKERS

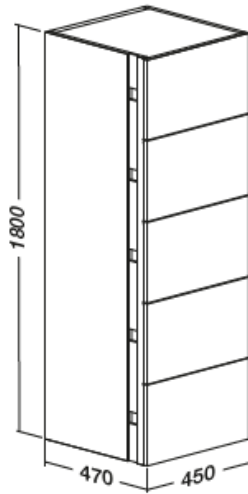
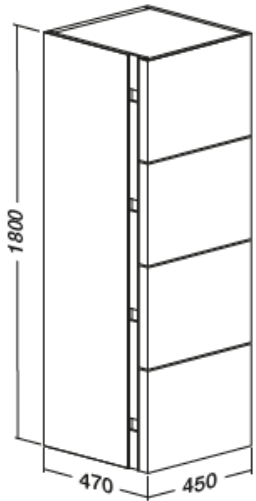

Technical details

- » MFC lockers are made from standard materials. 18 mm thick laminated chipboard is used in their production. If requested, the color finish of the doors can be different from the carcass color.
- » The standard and recommended dimensions of the lockers is a column 1800x470x450mm.
- » The sides of the lockers are designed to accommodate electricity cables. For the lockers it is necessary to order a 200mm high plinth with a width depending on the configuration width. The plinth has levelling screws that enable compensation for unevenness in the floor. It is also necessary to order facing panels for the sides and top of the configuration. The facing panel can be 18 or 36mm thick.
- » The VECOS electric lock is fitted to the configuration during manufacture. The panel, connection of cables and installation of software takes place during installation on site. Color decor options for carcass, doors, plinth and cladding.
- » LTD white – W980 ST15
- » LTD grey – U1188
- » LTD beech – BK358
- » LTD wild pear – R5413
- » Other decors – individual quotation.





ACCESSORIES

OUTLINE SERIES



Outline is a series of lamps and clocks that stand out because of their minimalist silhouette. The inspiration for this stylish design came from the outline of the archetypal table lamp. By taking it back to basics it is instantly recognizable. The outline is what remains, hence the name. The minimalist design suits about any interior.

The Outline series is manufactured in CO2 neutral factory using 100% recyclable steel. Exactly how it was intended, nothing less and nothing more. A true example of efficient use of materials.

OUTLINE



Technical details

- » Matte painted steel, only available in black – RAL 9005
- » Light bulbs are included for all models
- » Batteries are included for all clocks

Dimensions:

- » Table lamp small: 38 x 20 x 16 cm
- » Table lamp medium: 53 x 28 x 23 cm
- » Floor lamp: 145 x 56 x 45 cm
- » Clock high: 16 x 27 x 9 cm
- » Clock low: 31 x 15 x 9 cm
- » Weight:
 - Table lamp small: 1.1 kg
 - Table lamp medium: 2 kg
 - Floor lamp: 8 kg
 - Clock: 1 kg



ELEMENT DISC



Element Disc task light brings together advanced technology and optimal functionality. An innovative and adjustable LED desk lamp, Element Disc complements any work space, home office or hospitality environment. Using Thin Film LED Technology, Element Disc offers seven levels of brightness with just an effortless pinch of the light head. It also features a PIR occupancy sensor that turns the unit on or off when the user enters or leaves the area.

Element Disc packages advanced technology into a minimal light engine to deliver 330 lumens while using only 7 watts of power. With a CRI of 80 and a CCT of 3000K, Disc provides brilliant, uniform light for up to 50,000 hours - or the equivalent of 25 years in an average work environment. And with a clever folding mechanism, Disc is as convenient as it is beautiful.

ELEMENT DISC

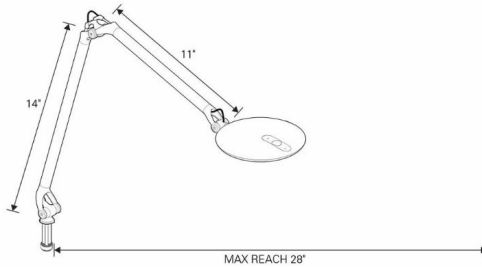

Technical details

- » Power consumption: 7 watts
- » Color temperature: 3000K
- » Color rendering index: 80
- » Lifespan: up to 50 000 hours
- » Maximum reach: 70 cm
- » Working height: 45 cm

Features

Latest LED Technology

Through the use of revolutionary Thin Film LED Technology, Element Disc produces a consistent ultra-wide light footprint. This new technology not only provides ample amounts of bright 3000K light that helps reduce eye strain, but also increases the lamp's usable life.

Smart Dimming

Element Disc's smart dimming feature provides seven adjustable illumination levels for energy-efficiency and ergonomic function. Intelligent and intuitive, Element Disc features a built-in PIR occupancy sensor that automatically turns the unit off when the user is not in the area.

One-Touch Adjustability

Disc's internal counterbalance system provides effortless, one-touch positioning and it folds away into a compact nesting position for easy storage. Available in one of 20 mounting options to suit any work environment, Element Disc is an incredibly versatile adjustable LED desk lamp.

MOUNTING OPTIONS



BASE



WALL MOUNT



PANEL MOUNT



DIRECT MOUNT



CLAMP MOUNT



2-PIECE CLAMP

HORIZON



The most celebrated and beautiful table light in the industry, Horizon is a visually striking embodiment of Humanscale's commitment to high performance and functionality. Recipient of the prestigious Red Dot Award as well as a Next Generation Luminaires Award for product design and performance, Horizon resides in the permanent collection of the Museum of Modern Art (MoMA). This iconic piece is available in eight vibrant colors and seamlessly complements any design aesthetic.

Suitable for home, office and hospitality spaces, Horizon's brilliant light throw is powered by Thin Film LED Technology — producing an ultra-wide glare-free footprint that is smooth and even.

HORIZON



Technical details

- » Power consumption: 7,5 watts
- » Color temperature: 3000K (bright white)
- » Color rendering index: ▶ 92
- » Lifespan: upto 50 000 hours (10 years)
- » Maximum reach: 40 cm
- » Working height: 46 cm

Features

Exceptional Light Quality

Horizon 2.0 offers light that is brighter and more true-to-life than its predecessor. Ultra- wide and glare-free, this beam casts a single shadow on a work surface and negates the need for additional task lighting.

Iconic Status

The first table light to use Thin Film LED Technology, Horizon is a Red Dot Award winner that is included in the permanent collection of the Museum of Modern Art (MoMA).

Ergonomic and Adjustable

An internal counterbalance and adjustable steel ball joints allow Horizon's single arm to be moved effortlessly. The fixture has an impressive 15" reach, allowing the light to be directed exactly where needed.

Highly Sustainable

The new, improved Horizon is PVC-free and Energy Star 2.0-certified. Delivering 52 lumens/watt, it is extremely energy efficient and contributes to LEED, WELL, and Living Building Challenge certifications.

Suited to all Decors

With its striking minimal design, Horizon 2.0 is at home in residential, contract, and hospitality environments. It's also available in six vibrant colors.

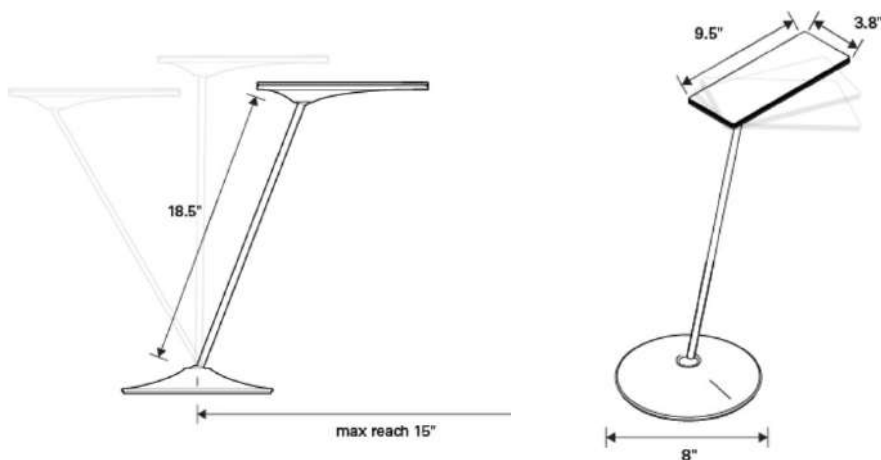

INFINITY



Infinity LED task light embodies performance in a sleek, timeless design. Equipped with constant torque 'Forever Hinges' for strength and stability in any position, Infinity's large-array, multi-chip LED provides long-lasting, high-quality light — casting just one single shadow. Infinity is designed from a functional perspective to create a task light that is elegant, enduring and globally appealing. The Infinity light's 'Forever Hinges' — a combination of torque inserts and springs that ensure a balanced, easy-to-move arm — allow for seamless adjustment, so the user can position the light to suit their personal ergonomic preference. Maintaining a minimalist aesthetic, cables are hidden from view and run internally throughout the length of the precision machined arm.

INFINITY

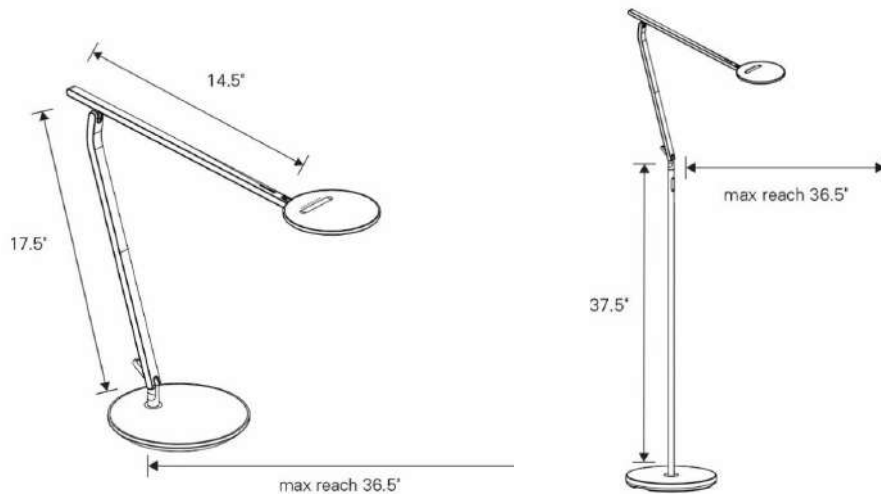

Technical details

- » Power consumption: 9 watts
- » Color temperature: 3000K (warm white)
- » Color rendering index: 90
- » Lifespan: up to 50 000 hours (10 years)
- » Illumination: 1500 lux
- » Maximum reach: 88 cm
- » Mounting options: desktop base, clamp, wall mount, slatwall mount or floor stand

Features

» Superior Illumination

Infinity's powerful 1500 lux illumination provides industry-leading output that is energy-efficient, casting just one single shadow on the desk surface.

» Fluid Movement

Forever Hinges' allow Infinity to maintain fluid movement and effortless positioning, unlike any other task light in the industry.

» Ultimate Adaptability

Infinity's impressive 35" arm reach and full 180 degree arm and head rotation allow for effortless, one-touch positioning. Available with customizable color finishes, the light can be easily tailored to any design aesthetic or work environment.

» Energy Efficient

With the highest efficiency LED chip on the market, Infinity uses just 8 watts to deliver best-in-class lighting performance.

» Sustainable Durability

Each Infinity light is made of polished aluminum and highly recycled and recyclable content. We use polyethylene (PE) film on the head and base instead of paint. It also lasts 50,000 hours, never needs to be adjusted, and has an industry-leading 10-year warranty.

ALFA 1100



Optimal lighting for your workstation. The ALFA 1100 LED table lamp includes 4th generation LED technology. This enables energy savings of up to 80%. The highly efficient LED light source with even or concentrated lighting mode can produce soft lighting similar to daylight. The simple design and organic shape using modern materials enables the direction and tilt of the lamp to be adjusted to provide the best lighting angle.

Using touch control, 5 brightness settings can be selected and the light quality can be switched between cold, warm and daylight. This technology also guarantees a long service life (over 10,000 hours).

ALFA 1100



Technical details

- » Max. power: 12 W
- » Max. illuminance: 2000 lux
- » Luminous power: 700 LM
- » Supply: 12 V DC-1500mAh
- » Light temperature:
 - 5500 K cold light
 - 3300 K warm light
 - 4000 K combined light
- » Operating temperature: $<50^{\circ}\text{C}$
- » Light intensity memory

Instructions

The arm can be moved up and down through a range of 150° . The lamp head can be twisted from side to side by up to 45° in each direction and it can be tilted from side to side by up to 30° in each direction. When tilting the lamp head with one hand, hold the base with the other.

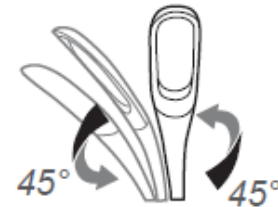
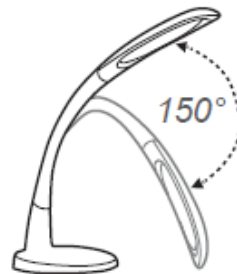
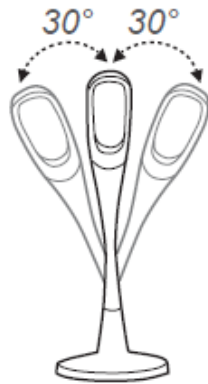

MONITOR ARM



In today's fast-paced, fully connected digital world, there's no time for discomfort. Ergonomic monitor arms and mounts enable instant personalization of the workspace for improved comfort, health, and productivity. Monitor arms not only promote a clutter-free workspace, they support a healthier, more ergonomic working posture. Users are encouraged to align the monitor at the correct height for them, which helps prevent eye and neck strain. All of our monitor arms are ultra-sleek, exceptionally durable, and easy to adjust.

MONITOR ARM



Technical details

- » Sleek monitor arm allows user to bring their work to them, versus having to adjust to a static monitor stand, allowing the user to work in a healthy posture
- » Height and depth adjustment
- » Extension-spring technology
- » Effortless screen sharing for easy collaboration
- » Space saving
- » Seamless cable management
- » Interchangeable links for additional reach

Colors:

- » Polished Aluminum with White Trim
- » Silver with Gray Trim
- » Black with Black Trim

Options

- » **M2**
Monitor weight range up to 9 kg
- » **M8**
Single or dual monitor up to 18 kg
- » **M8 Crossbar**
Dual monitors side-by-side – can be adjusted independently
Compatible with M/Connect™ USB 3.0 monitor arm base, docking station that eliminates desktop clutter, conceals IT connections and provides easy access to user ports
- » **M/FLEX**
Multi monitor arm system
Weight range up to 55 kg
From 1 to 6 monitors without the need for tools
M/Connect™



ALVA COLLECTION



Elegant design and easy to put together, these are the main characteristics of the coat stand whose components are the basis for the entire Alva Collection. In this range primary emphasis is placed on functionality, simplicity of use, stability and strength. For this reason it was decided to use aluminum alloy in the form of extrusions and die castings. The coat stand is the base-product of this new range of accessories intended for commercial interiors – offices, shops, hotels and conference facilities.

ALVA COLLECTION

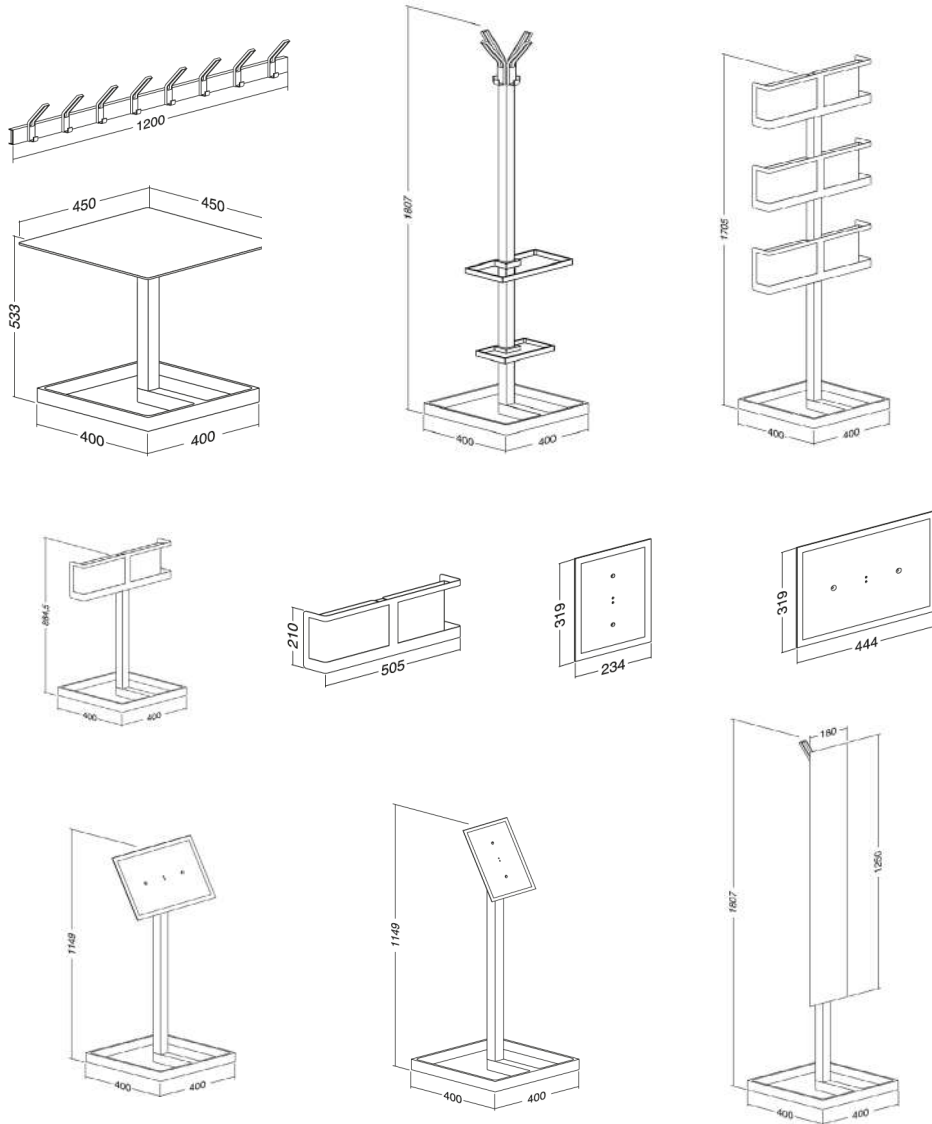

Color options

- » RAL9004 – black
- » RA9007 – gunmetal
- » RAL9010 – white
- » RAL9022 – silver

Materials

- » Aluminum alloy
- » Steel

Collection:

- » Table
- » Coat stand (optional umbrella holder)
- » Wall rack (1200/600 mm)
- » Wall leaflet holder
- » Leaflet single/trio holder – free stand
- » Advert A4/A3 wall panel
- » Advert A4/A3 holder – free stand
- » Mirror



NOVUM COLLECTION



The Novum collection of office accessories brings order to your work environment. They complement the TECHO desk systems and provide elegant storage space whilst retaining the TECHO functional style. The Novum office accessories can be attached to the Zenith 2 screens, which adds another dimension to the workstation. Don't let your stationery and paperwork take over your desk – fight back with Novum office accessories.

NOVUM COLLECTION

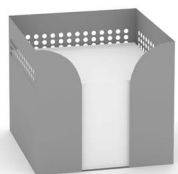
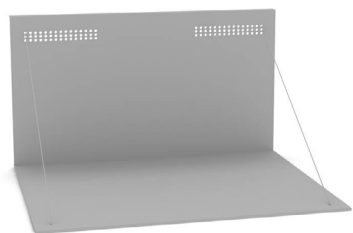

Technical details

» Individual products from the NOVUM are made from steel sheet and are finished with a high-quality powder coating.

Color options

- » RAL9022 silver
- » RAL9010 white
- » RAL9004 black
- » RAL9007 gunmetal

Collection

- » Pen pot
- » Memo holder with paper (hanging option)
- » Sorter (hanging option)
- » Filing tray
- » Hung shelf
- » Waste bin

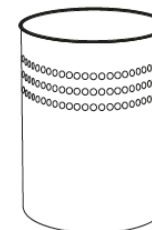
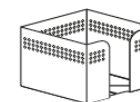
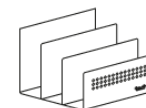



SOFT SEATING

CITY



City is a minimalist sofa, designed by Christophe Pillet and is characterized by a cubical and gentle form that invites interaction between people. City, with its puffy seats and backs, provides a relaxed and comfortable feeling.

City carries the same characteristic features of Christopher Pillet's designs in elegance and functionality. This sofa group is like an answer to all your needs with its sleek design and rich product family and modularity whether as a single chair, two or three seats or as a large corner configuration. With this contemporary sofa unit, dynamic layouts suitable for modern designed individual or public areas, from a cozy apartment to a spacious lounge can be created. Comfort, elegance and serenity come to life with City. Esthetic legs are the parts of its modern look and with its color options, it helps catching the desired effect where it is used.

It is one of the most creative thinking and innovative designed sofas in the market. With its elegant and sturdy shaped form, City provides tremendous comfort and perfect harmony in creating a functional living spaces.

CITY

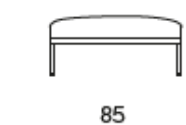
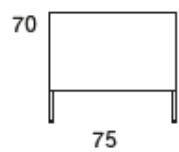

38

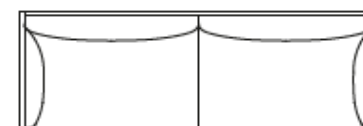
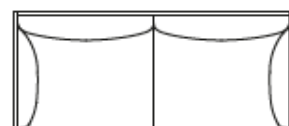
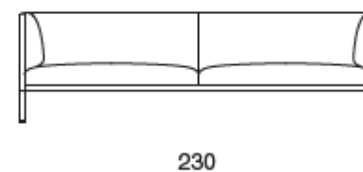
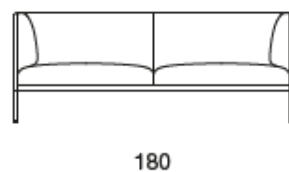
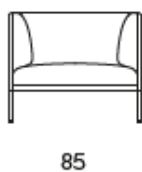

MONA

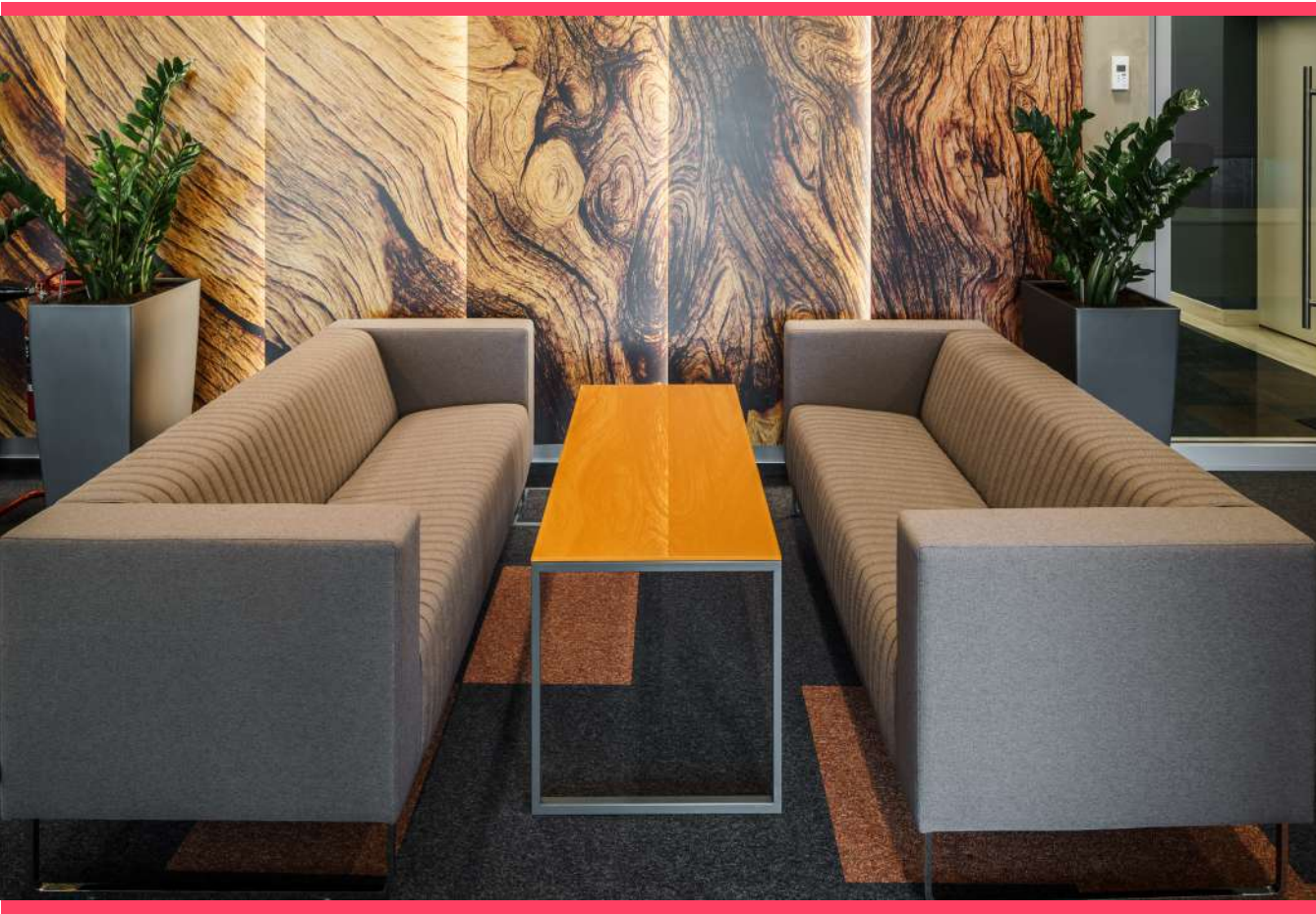

The elastic backs and the high resistant foam in the seat give a seating comfort, completed with a perfect look and minimal elegance. Slim metal bases complete the robust design in a contrasting way. The padded upholstery shows the craftsmanship by giving a classical aesthetic look to a modern Studio debere-nn design. A timeless office sofa with a wooden frame is upholstered with non-deformable foam and polyester fiber, and a seat with elastic belts and elegant chrome metal legs. Covers include irremovable fabric or leather. Quilting and sewing details customize and stylize the product. Mona is created to offer a different and discreet design that fits the space perfectly, without being out of tune, harmonizing with the environment. It gives a new soul to living areas with its dynamic form language and special quilted upholstery. Mona is the sophistication with its eye-ful style and comfort with its wide sitting area.

MONA

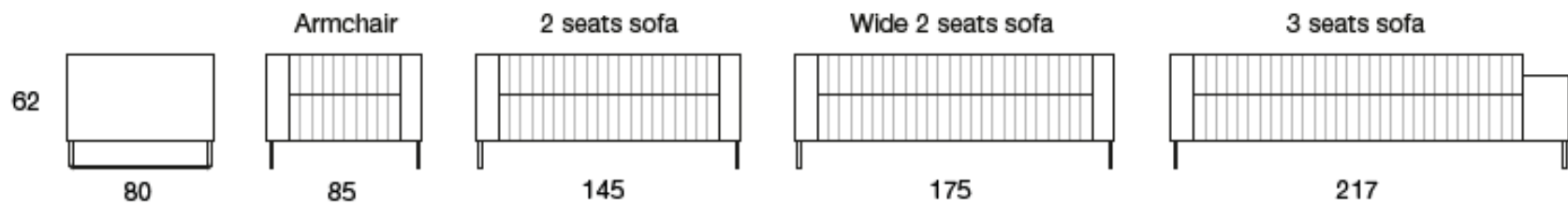

PINTO



A product needs to work in harmony with each other. The Pinto, designed by David Fox, can work well individually or as part of a larger scheme. The key shapes can link the range together and work with other projects in our progressive deberenn portfolio. Pinto's main product, Bean, is the primary generator for this upholstery system. A simply detailed design, the upholstery is elevated from the floor with a delicate tubular frame. Angled yet considered lines rise in a positive direction from the base of the product, with angled supporting backs swoop around the body for comfort. Pinto can be loosely scattered as an independent sofa with stools or linked in a modular landscape for a more organized solution, either option caters to demands of a compact office or large living areas. Often with impressive design products, one might get tired of the aesthetic over time, yet with Pinto it aesthetically slides into any environment. This design makes it marketable for several interior applications, just like a simple black dress can be worn regularly for a long time.

PINTO

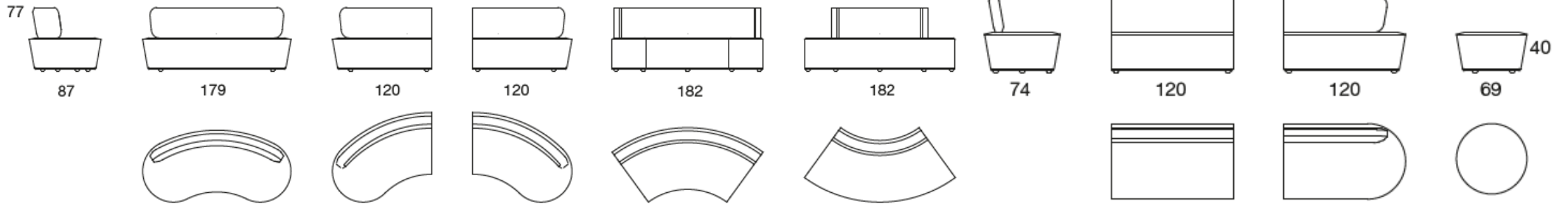

POSITIVA



Positiva is a family that grows like a flower from the ground, beginning with the armchair and sofa. It's a simple, well-proportioned concept that sits on an elegant rotating four-star base. After adding the hood to the armchair, the chair becomes an acoustic tranquil space. If you want some alone time for a private time to make a phone call, or surf the net, the hooded chair can be rotated so you are not facing an audience. Designed by David Fox, Positiva is a playful chair ideally suited to the contemporary workplace. It can be used independently to create private spaces in open plan environments, or alongside each other to enhance collaborative working. Positiva is a complement making perfect sense for the open and communicative lounge modules, adding an ideal element for middle zones, reception areas or even schools.

POSITIVA

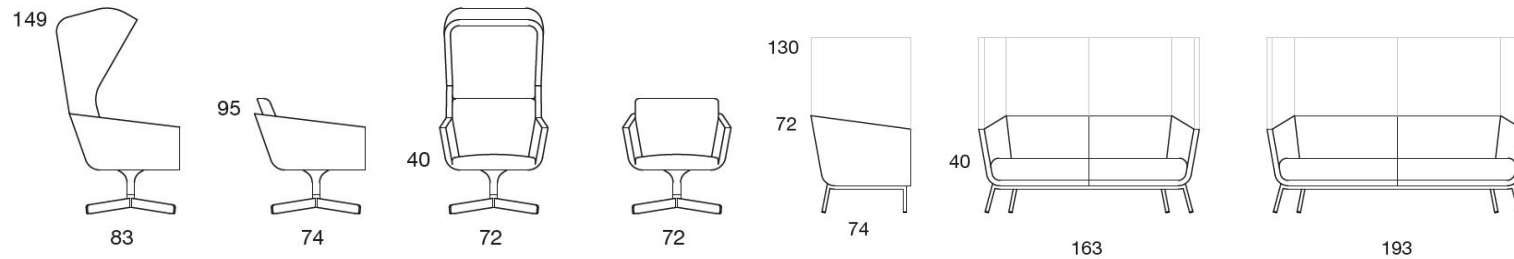

HENDRIX



A higher back, and rounded headrest offers some privacy for making calls, holding private meetings etc. Fluidity is the key with Hendrix, the wine glass shaped stem flows into the seats under curves, blending in a positive direction until it meets its "iconic fringe line" connection, where the headrest meets the main body of the chair. A Laser formed steel four star base elevates the product from the floor, swiveling so that the user can turn away from a meeting situation for further privacy.

HENDRIX

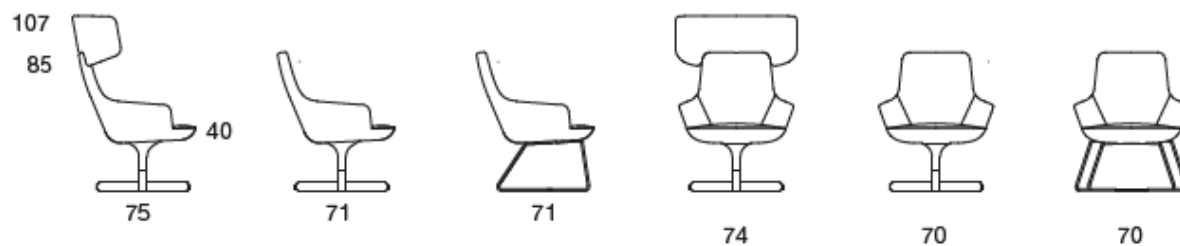

BANG BANG



Bang Bang stools are inspired by the outer wires of a drum and designed by David Fox. Organically donut shaped upholstery cushions, the user sits against its' engineered wire frame. The bases can be upholstered to synergize with other products, providing a softer option and offering flexibility. Upholstered in a range of contract fabrics and leathers, the steel parts of Bang Bang can be chromed, or epoxy powder coated. It is often the small things in life that give us so much pleasure since they make us aware of true quality, sensitize us to the intensive nature of craftsmanship. Bang Bang is a compact, elegant stool that showcases great design, comfort and is exceptionally practical. This easy stool has a distinctive dynamic form which will liven up any environment. It is ideally can be used in living rooms, atriums or hotel lobbies and breakout spaces. Bang bang is available in a selection of fabrics and as an option base frame can be upholstered.

BANG BANG



42

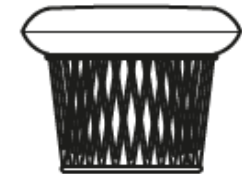
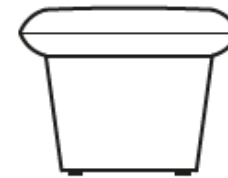

55

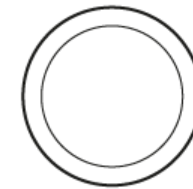

COFFEE TABLES



ALLES

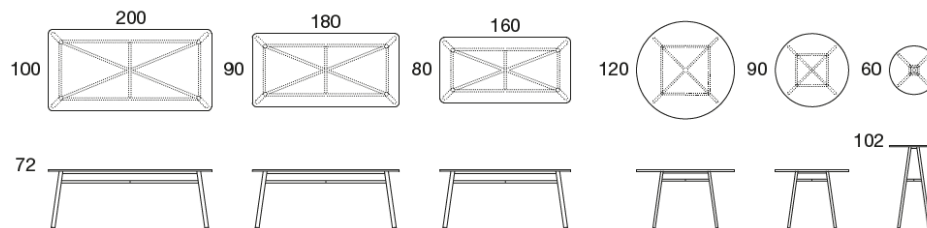
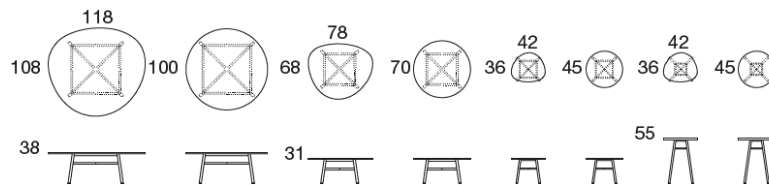

C- ANENOME - TABLE/STOOL

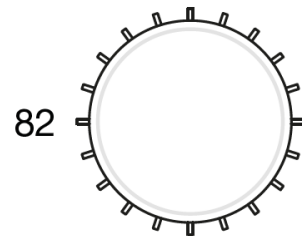

82

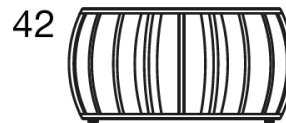

42

75

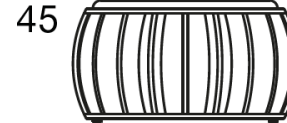

45

HENDRIX

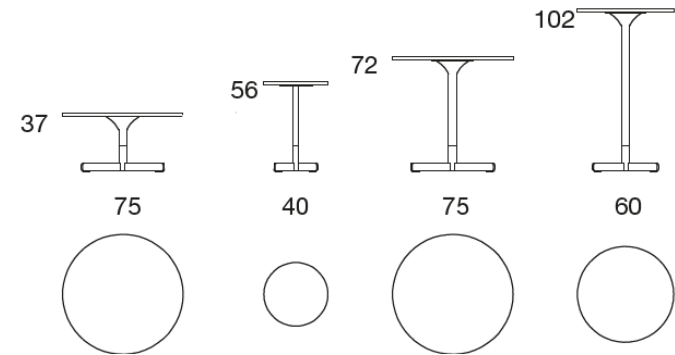
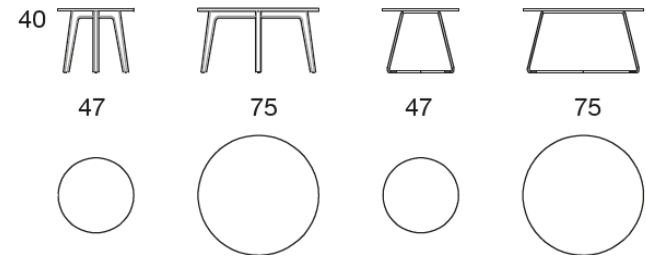

MONO

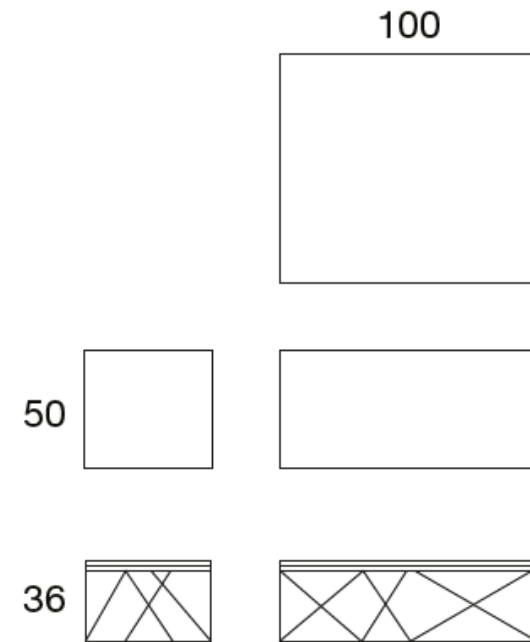

PINTO

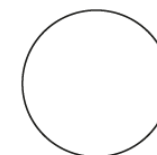
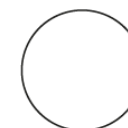
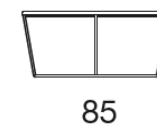
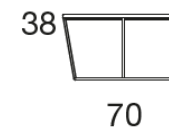
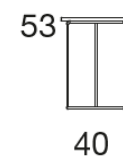
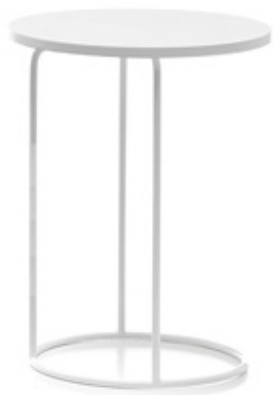

SOLO

